

W-5

**PROCUREMENT OF CIVIL WORKS
THROUGH
REQUEST FOR QUOTATION
(RFQ)/SHOPPING PROCEDURES**

*(One-Envelope bidding process without e-Procurement)
(For Contracts valued less than the equivalent of US \$ 100,000 each)*

April 2018

OFFICE OF THE MANAGING DIRECTOR “HAMREN NATURAL FOOD PROCESSORS PRIVATE LIMITED”, AMBINGNONG, WEST KARBI ANGLONG (DIST.) ASSAM - 782486

Mob:-7896870084

E-mail-hamrenfoodprocessors2021@gmail.com

REQUEST FOR QUOTATIONS
Procurement of Works under RFQ/Shopping Procedures
Procurement Notice
(One-Envelope Bidding Process without e-Procurement)

Project: Assam Agribusiness and Rural Transformation Project (APART)

Contract title: Construction of Fruits & Vegetables Processing Unit at Ambinong, West Karbi Anglong, Assam.

RFQ No: CFC/APART/01/2023

Date: 02-06-2023

Applicable Procurement Guidelines/Regulations Date: July 2016

1. The Government of India has received financing from the World Bank toward the cost of the Assam Agribusiness and Rural Transformation Project (APART) and intends to apply part of the proceeds toward eligible payments under the contract for construction of works as detailed below.

Package No.	Brief Description of the Works	Cost of document (Rs.)	Period of Completion
APART/CDTA/CFC/ KARBI ANGLONG/01/2023	Construction of Fruits & Vegetables Processing Unit at Ambinong, West Karbi Anglong, Assam.	1000/- (Including GST)	6 (six) months Including rainy season

2. This RFQ notice includes the following documents¹ to facilitate preparation and submission of quotations, criteria for qualification, evaluation, and for award of contract; and relevant forms to be filled by the bidders. Implementing Agency has not issued a separate document for this purchase. The RFQ notice including the various documents and forms to be filled etc. can be downloaded from **02/06/2023 10.00 AM to 16/06/2023, 5.00 PM** for free of cost by logging on to the website **www.industriescom.assam.gov.in**

- i. Layout Drawings of the works;
- ii. Structural Details;
- iii. Detailed Bill of Quantities, with estimated rates and prices;
- iv. Technical Specifications;
- v. Instructions to Bidders;

¹ IA to modify the list of documents as required.

- vi. Qualification Information;
 - vii. Format for Submission of Quotation;
 - viii. Criteria for Evaluation and Award of Contract;
 - ix. Relevant Forms; and
 - x. Draft Contract Agreement format which will be used for finalizing the agreement for this Contract.
3. Quotations shall be submitted to O/o The Additional Director of Industries & Commerce, District Industries & Commerce Centre (DI&CC), Karbi Anglong, Diphu on or before **11.00 AM on 17/06/2023**. Any quotation or modifications to quotation received beyond the date and time mentioned will not be considered. The Quotations will be opened on **17/06/2023 at 11.30 AM** in the presence of the bidders who wish to attend.
 4. If the implementing agency's office happens to be closed on the date of opening of the Quotations as specified, the 'Quotations will be opened on the next working day at the same time.
 5. Other details can be seen in the RFQ document. The implementing agency shall not be held liable for any delays for submission of Quotation. A Bidder requiring any clarification of the RFQ document may notify the Implementing agency through email or may visit the office of the implementing agency at the address given below.

O/o The Additional Director of Industries & Commerce, District Industries & Commerce Centre (DI&CC), Karbi Anglong, Diphu-782460
Contact Person- Rajani Kanta Deori
Contact Number-86385-71097
e-mail: hamrenfoodprocessors2021@gmail.com

Instructions to Bidders

SECTION - A

1. Scope of Works

The Managing Director, M/s “Hamren Natural Food Processors Private Limited”, Ambingnong, Hamren, West Karbi Anglong-782486 (Employer) invites quotations for the construction of works as detailed in the table given below

Package No.	Brief Description of the Works	Bid Security	Cost of Bid Document	Period of Completion
APART/CDTA/ CFC/ KARBI ANGLONG/01/ 2023	Construction of Fruits & Vegetables Processing Unit at Ambinong, West Karbi Anglong, Assam.	Rs. 60,000/-	1000/-	6 (six) months Including rainy season

The successful bidder will be expected to complete the works by the intended completion date specified above.

2. Qualification of the bidder

2.1. Qualification Information to be provided by the Bidder: the bidder shall provide information on his qualification which shall include: -

- (a) Total monetary value of works executed by him for each year of the last 3 years;
- (b) List of works (similar to the works described in Para 1) completed satisfactorily as a prime contractor during the last 3 years, enclosing certificates from the respective Employers in support of experience claimed along with the Employers’ contact numbers;
- (c) Report on his financial standing, along with last 3 years’ financial statements/Profit and Loss Statements; and
- (d) Details of any litigation, during the last 3 years in which the bidder is involved, the parties concerned, and disputed amount or award in each case (Give details of both completed and pending cases).

2.2. Qualification Criteria: to qualify for award of the contract the bidder: -

- (a) should have satisfactorily completed as a prime contractor at least one similar work of value not less than **Rs 50 Lakhs** in the last three years;

- (b) should have achieved in at least one year an annual financial turnover (in civil engineering construction works of similar nature only) of not less than **Rs 60 Lakhs** in the last three years;
- (c)* should possess valid electrical license for executing building electrification works (in the event of the works being sub - contracted, the sub-contractor should have the necessary license);
- (d)* should possess required valid license for executing the water supply/sanitary works (in the event of the works being sub-contracted, the sub-contractor should have the necessary license);
- (e) should not have been debarred (or dealings suspended) on the date of bid opening by the Central/State Governments/undertakings or by the World Bank Group.
- (f) no contract should have been suspended or terminated and/or performance security called by an employer(s) for reasons related to Environmental, Social, Health, or Safety (ESHS) performance in the past five years.
- (g) availability of liquid assets and/or credit facilities, net of other contractual commitments and exclusive of any advance payments which may be made under the Contract, of not less than **Rs 18 Lakhs**.

(## Credit lines/letter of credit/certificates from Banks for meeting the funds requirement etc.- usually the equivalent of the estimated cash flow for 3 months in peak construction period)

3. Eligibility – Conflict of Interest: A Bidder (a) shall not participate in more than one Quotation; (b) shall not have conflict of interest as defined in the Bank’s Procurement Guidelines; and (c) should not have been (i) temporarily suspended or debarred by the World Bank Group in compliance with the Bank’s Anti-Corruption Guidelines and its Sanctions Framework; or (ii) blacklisted or suspended by Central or any State Government Departments in India.

4. Clarifications & Amendments: If the Employer receives any request for clarification of this RFQ document, it will upload its response together with any amendment to this document, on the website for information of all Bidders. Bidders should check on the website, for any amendments to this RFQ document.

5. Quotation Prices

- a) The quotation shall be for construction of the whole works as described in the Bill of quantities, drawings and technical specifications. Corrections, if any, in the quotation shall be carried out by editing the information before submission.

- b) All duties, taxes and other levies payable by the contractor under the contract shall be included in the total price.
- c) The rates quoted by the bidder shall be fixed for the duration of the contract and shall not be subject to adjustment on any account.
- d) The rates should be quoted in Indian Rupees only.

6. Preparation of Quotations

6.1 The bidder is advised to visit the site of works at his own expense and obtain all information that may be necessary for preparing the quotation.

6.2 Each bidder shall submit only one quotation. Bidders shall not contact other Bidders on matters relating to this quotation.

6.3 The quotation shall comprise one Parts both the Technical Part and the Financial Part combinedly.

6.4 The Quotation shall comprise the following:

- (a) **Letter of Quotation** –as per Format given in Section B;
- (b) **Authorization:** Power of Attorney of signatory of Quotation (Paragraph 1.1 of Qualification Information);
- (c) **Annual Turnover:** Confirmation showing Annual Turnover in civil engineering construction works of similar nature in the last three financial years. [ITB Clause 2.1 (a)];
- (d) **Qualifications:**
 - (i) Qualification information and supporting documents relating to similar nature of works executed and payments received. (ITB Clause 2.1 (b) and paragraph 1.3 of Qualification Information);
 - (ii) Details of proposed sub-contractors; (Paragraph 1.4 of Qualification Information); and
 - (iii) Other details listed in Paragraphs 1.6 and 1.7 of the Qualification Information Form;
- (e) **Complete address** and contact details of the Bidder having the following information:

Name of Firm
Address for communication
Telephone No(s): Office
Mobile No.
Facsimile (FAX) No.
Electronic Mail Identification (E-mail ID)

- 6.5 Signing of Quotations:** The name and position held by each person signing the quotation and related documents must be typed or printed below the signature.
- 6.7 Bid Security:** Bid Security, in original form for the amount **Rs 60,000/**, in one of the following forms:
- A bank guarantee issued by a nationalized/scheduled bank located in India in the form given in Section B; or
 - Certified cheque or Bank draft payable to **“M/s HAMREN NATURAL FOOD PROCESSORS PRIVATE LIMITED”** at State Bank Of India, HAMREN Branch, WEST KARBI ANGLONG
 - Fixed Deposit/Time Deposit certificates issued by a Nationalized or Scheduled Bank located in India for equivalent or higher values are acceptable provided it is pledged in favour of **“M/s HAMREN NATURAL FOOD PROCESSORS PRIVATE LIMITED”**, and such pledging has been noted and suitably endorsed by the bank issuing the deposit certificate.
- 6.8 Bid submission:** The bidder shall seal the bid in an envelope addressed to
- The MANAGING DIRECTOR,
“M/s HAMREN NATURAL FOOD PROCESSORS PRIVATE LIMITED”
AMBINONG, HAMREN-782486, WEST KARBI ANGLONG.
 - The envelope will also bear the following identification: -
Bid for CONSTRUCTION OF FRUITS AND VEGETABLE PROCESSING UNIT, AT AMBINONG, HAMREN, WEST KARBI ANGLONG-782486.
 - Do not open before **11.30 AM, 17/06/2023**
- 6.9 Deadline for Submission of Quotations:** Quotations must be received in the office of the O/o The Additional Director of Industries & Commerce, District Industries & Commerce Centre (DI&CC), Karbi Anglong, Diphu-782460 not later than the time and date given in the RFQ. If the specified date is declared a holiday, bids shall be received up to the appointed time on the next working day.
- 6.10 Validity of Quotation:** Quotation shall remain valid for a period not less than 45 days after the deadline date specified for submission.
- 7. Quotation Submission:**
- (a) The Letter of Quotation shall be filled, signed submitted along with the Priced Bill of Quantities without any alterations.
 - (b) All documents are required to be signed by the Bidder.
- 8. Opening of Quotations:** The Quotations will be opened on the specified date and time. Quotations will be publicly opened in the presence of bidders or their representatives who choose to attend on the date and time and at the place specified in sub-clause 6.8 above.

- (a) The Employer shall examine the technical part of the quotation to determine whether the quotation (a) has been properly signed (Clause 6.6); (b) meets the eligibility criteria (Clause 3); (c) is substantially responsive to the requirements of the RFQ document; and (d) meets the qualification criteria specified in ITB Clause 2.
- (b) Only Quotations that are substantially responsive to the RFQ document, and meet all Qualification Criteria shall qualify for award of the contract.

9. Award of contract

The Employer will award the contract to the bidder whose quotation has been determined to be substantially responsive and who has offered the lowest evaluated quotation price and who meets the specified qualification criteria.

9.1 Notwithstanding the above, the Employer reserves the right to accept or reject any quotations and to cancel the bidding process and reject all quotations at any time prior to the award of contract.

9.2 The bidder whose quotation is accepted will be notified of the award of contract by the Employer prior to expiration of the quotation validity period.

10. Performance Security

Within 15 days of receiving letter of acceptance, the successful bidder shall deliver to the “M/s HAMREN NATURAL FOOD PROCESSORS PRIVATE LIMITED” the performance security (either a bank guarantee or a bank draft in favour of the Employer) for an amount equivalent of 5 % of the contract price. The Performance Security shall be valid till the expiry of the period of maintenance of the work, specified in Clause 12. Failure of the successful Bidder to furnish performance security and to sign the agreement within the period stipulated shall constitute sufficient grounds for annulment of award and debarring the bidder from participation in bidding for works by the Employer for a period of one year, in which case the Employer may make the award to the next lowest evaluated bidder or seek quotations afresh.

12. Period of Maintenance:

The “Period of Maintenance” for the work is six months from the date of taking over possession or one full monsoon season whichever occurs later. During the period of maintenance, the contractor will be responsible for rectifying any defects in construction free of cost to the Employer.

13. Supply of all construction materials including cement and steel as per the specifications (ISI certification marked goods wherever available) shall be the responsibility of the contractor. Employer will not issue any material/equipment.

.....

SECTION - B

- 1. Format for Qualification Information.**
- 2. Format for Submission of Quotation.**
- 3. Format of Letter of Acceptance.**

QUALIFICATION INFORMATION

1 For Individual Bidders

1.1 Principal place of business: _____

Power of attorney of signatory of Quotation.
[Attach copy]

1.2 Total value of Civil Engineering construction work performed in the last three years (in Rs. Lakhs)

	2019-2020	_____
	2020-2021	_____
	2021-2022	_____

1.3 Work performed as prime contractor (in the same name) on works of a similar nature over the last three years.

<u>Project Name</u>	<u>Name of Employer</u>	<u>Description of work</u>	<u>Contract No.</u>	<u>Value of contract (Rs. Lakhs)</u>	<u>Date of issue of work order</u>	<u>Stipulated period of completion</u>	<u>Actual date of completion*</u>	<u>Remarks explaining reasons for delay and work completed</u>

Existing commitments and on-going works:

Description of Work	Place & State	Contract No. & Date	Value of Contract (Rs. Lakhs)	Stipulated period of completion	Value of works* remaining to be completed (Rs. Lakhs)	Anticipated date of completion
(1)	(2)	(3)	(4)	(5)	(6)	(7)

* Enclose a certificate from the Engineer concerned for completion as well as value of pending works.

1.4 Proposed subcontracts and firms involved.

Sections of the works	Value of Sub-contract	Sub-contractor (name & address)	Experience in similar work

1.5 Evidence of access to financial resources to meet the requirements of working capital: cash in hand, lines of credit, etc. List them below and attach copies of support documents.

1.6 Name, address, and telephone, telex, and fax numbers of the Bidders' bankers who may provide references if contacted by the Employer.

1.7 Information on litigation history in which the Bidder is involved.

Name of the work	Agreement number/date	Name & address of Employer	Contract Value in Rs	Cause of dispute	Amount Disputed	Remarks showing present status

1.8 Provide details of the Key Personnel and such other Key Personnel that the Bidder considers appropriate, together with their academic qualifications and work experience.

Item No.	Position/ specialization	Relevant academic qualifications	Minimum years of relevant work experience
1	Manager-in-charge (1 No.)	Degree in Civil	10 years
2	Site Engineer (1 No.)	Degree in Civil	5 Years
3	Site Supervisor (2 nos.)	Diploma in Civil	5 years
4	Environment, Health and Safety Engineer	Graduate in Civil or Environmental Engineering with specialization and/or additional qualification in Occupational Health and Safety.	[7]

- 1.9** The Bidder must demonstrate that it will have access to the key Contractor's equipment listed hereafter:

No.	Equipment Type and Characteristics	Minimum Number required
1	Tipper Truck (5.5 cum/10 T capacity)	2 Nos.
2	Excavator (Standard)	1 No.
3	Concrete Mixture (10/7)	1 No.
4	Generator Set	1 No.
5	Needle vibrator and Plate vibrator	3 each
6	Welding Set	1 No.
7	Water Tank (5 KL)	1 No.
8	All piling equipment (standard)	1 set.

Letter of Quotation

The Bidder must prepare the Letter of Quotation on stationery with its letterhead clearly showing the Bidder's complete name and address. The italicized text is for Bidder's guidance in preparing these forms and shall be deleted from the final products.

Description of the Works: **Construction of Fruits & Vegetables Processing Unit at Ambinong, West Karbi Anglong, Assam.**

RFQ No.: CFC/APART/01/2023

Our Reference: No.....

Dated.....

To: (Employer's name and address)

Subject : **Construction of Fruits & Vegetables Processing Unit at Ambinong, West Karbi Anglong, Assam.**

Reference : Letter No.....dated.....from.....

Sir,

1. We, the undersigned, hereby submit our Quotation in one envelope bidding process for both
 - (a) Technical Part; and
 - (b) Financial Part
2. In submitting our Quotation, we make the following declarations:
 - (a) **No reservations:** We have examined and have no reservations to the RFQ document;
 - (b) **Conformity:** We offer to execute the subject work in conformity with the RFQ document and in accordance with the Period of Completion specified in Section A.;
 - (c) **Quotation Validity Period:** Our Quotation shall be valid for the period of 45 days, from the deadline fixed for the Quotation submission;
 - (d) **Eligibility:** We meet the eligibility requirements and have no conflict of interest, we are not participating in more than one quotation in this bidding process, and we have not been temporarily suspended or debarred by the World Bank or blacklisted or suspended the Central or any State Government;
 - (e) **Fraud and Corruption:** We hereby certify that we have taken steps to ensure that no person acting for us or on our behalf will engage in any type of corrupt, fraudulent, collusive, coercive, or obstructive practices; and we will strictly observe the laws against fraud and corruption in force in India namely, "Prevention of Corruption Act 1988."

Yours faithfully,

Authorized Signature : Date: _____

Name & Title of Signatory : _____

In the capacity of *[insert legal capacity of person signing the Letter of Quotation]*

Name of Bidder : _____

Address : _____

Dated on _____ day of _____, _____ *[insert date of signing]*

* ***To be filled in by the Employer before issue of the Letter of Invitation.***

** ***To be filled in by the Bidder, together with his particulars and date of submission at the bottom of this Form.***

**LETTER OF ACCEPTANCE
CUM NOTICE TO PROCEED WITH THE WORK**

(LETTERHEAD OF THE EMPLOYER)

Dated: _____

To: _____ [Name and address of the Contractor]

Dear Sirs,

This is to notify you that your quotation dated _____ for execution of the _____ for the contract price of Rupees _____ [amount in words and figures], is hereby accepted by us.

You are hereby requested to furnish performance security for an amount of Rs. _____ (equivalent to 3% of the contract price) within 15 days of the receipt of the letter. The Performance Security in the form of Bank guarantee or a Bank draft in favour of..... (Employer) shall be valid till the expiry of the period of maintenance i.e. up to _____. Failure to furnish the Performance Security will entail cancellation of the award of contract.

You are also requested to sign the agreement form and proceed with the work not later than _____ under the instructions of the Engineer, _____ and ensure its completion within the contract period.

With the issuance of this acceptance letter and your furnishing the required Performance Security, the contract, for the above said work, stands concluded.

Yours faithfully,

**Authorized Signature
Name and title of Signatory of Employer**

Draft Contract Agreement form for Construction through National Shopping

ARTICLES OF CONTRACT AGREEMENT

1. This deed of agreement is made in the form of agreement on _____ day _____ month _____ 20 ____, between the _____ (Employer) or his authorized representative (hereinafter referred to as the first party) and _____ (Name of the Contractor), S/O _____ resident of _____ (hereinafter referred to as the second party), to execute the work of construction of _____ (hereinafter referred to as works) on the following terms and conditions.

2. Contract Price

The total Contract Price for the works (hereinafter referred to as the “total price”) is Rs. _____ as reflected in Annexure - 1.

3.1 Payments under its contract:

Payments to the second party for the construction work will be released by the first party in the following manner:-

SL No	Description of Payment Milestones	Percentage of Payment to be released
1.	On signing of agreement	10% of the contract price on receipt of unconditional bank guarantee in the format attached
2.	On completion of complete foundation work of all structures and reaching plinth level	10% of the contract price
3.	On completion of all RCC super-structure works including Columns, lintels and Roof beam, RCC flooring/ Roof Slab wherever applicable. On completion of all brick masonry work including external and internal brick walls, (internal and external plastering, On completion of all external development works (like Boundary wall, Gate Complex, Internal roads, drains)	40% of the contract price
4.	On complete fabrication and erection of all steel structure works (including truss, purlins, roofing, wall cladding, etc), putty work, coloring work, fixing of all door, window, rolling shutter, ventilators, etc.,	20% of the contract price
5.	On completion of all Finishing Work including Coloring, Fixing of Electrical fittings & fixtures , street lights, Firefighting, Plumbing etc.), On completion of any other remaining work and handover of entire project.	20% of the contract price

3.2 Payments at each stage will be made by the first party:

- (a) on the second party submitting an invoice for an equivalent amount;
- (b) on certification of the invoice (except for the first installment) by the engineer nominated by the first party with respect to quality/quantity of works executed in the format in Annexure - 2; and
- (c) upon proper and justified utilization of at least 50 % of the previous installment and 100 % of any prior installment.
- (d) Payments shall be adjusted for deductions for advance payments, recoveries if any in terms of the contract, and taxes at source, as applicable under the law.
- (e) The advance (if availed by the contractor) shall be repaid with percentage deductions from the interim payments, commencing with the next Interim Payment at the rate of 20 percent of the amounts of all Interim Payment Certificates until the advance has been repaid, provided that the advance shall be completely repaid prior to the expiry of the Intended Completion Date. The Bank Guarantee shall remain effective until the advance payment has been fully repaid.

4. Notice by Contractor to Engineer

The second party, on the works reaching each stage of construction, issue a notice to the first party or the Engineer nominated by the first party (who is responsible for supervising the contractor, administering the contract, certifying the payments due to the contractor, issuing and valuing variations to the contract, awarding extensions of time etc.), to visit the site for certification of stage completion. Within 15 days of the receipt of such notice, the first party or the engineer nominated by it, will ensure issue of stage completion certificate after due verification.

5. Completion time

The works should be completed in 6 months from the date of this Agreement. In exceptional circumstances, the time period stated in this clause may be extended in writing by mutual consent of both the parties.

6. If any of the compensation events mentioned below would prevent the work being completed by the intended completion date, the first party will decide on the intended completion date being extended by a suitable period:

- a) The first party does not give access to the site or a part thereof by the agreed period.

- b) The first party orders a delay or does not issue completed drawings, specifications or instructions for execution of the work on time.
 - c) Ground conditions are substantially more adverse than could reasonably have been assumed before issue of letter of acceptance and from information provided to second party or from visual inspection of the site.
 - d) Payments due to the second party are delayed without reason.
 - e) Certification for stage completion of the work is delayed unreasonably.
7. Any willful delay on the part of the second party in completing the construction within the stipulated period will render him liable to pay liquidated damages @ Rs. 5,500/- per day which will be deducted from payments due to him. The first party may cancel the contract and take recourse to such other action as deemed appropriate once the total amount of liquidated damages exceeds 5 % of the contract amount.

8. Duties and responsibilities of the first party

- 8.1 The first party shall be responsible for providing regular and frequent supervision and guidance to the second party for carrying out the works as per specifications. This will include written guidelines and regular site visit of the authorized personnel of the first party, for checking quality of material and construction to ensure that it is as per the norms.
- 8.2 The first party shall supply 3 sets of drawings, specifications and guidelines to the second party for the proposed works.
- 8.3 Possession of the site will be handed over to the second party within 10 days of signing of the agreement.
- 8.4 The Engineer or such other person as may be authorized by the first party shall hold meeting once in a fortnight where the second party or his representative at site will submit the latest information including progress report and difficulties if any, in the execution of the work. The whole team may jointly inspect the site on a particular day to take stock of activities.
- 8.5 The Engineer shall record his observations/instructions at the time of his site visit in a site register maintained by the second party. The second party will carry out the instructions and promptly rectify any deviations pointed out by the engineer. If the deviations are not rectified, within the time specified in the Engineer's notice, the first party as well as the engineer nominated by it, may instruct stoppage or suspension of the construction. It shall thereupon be open to the first party or the engineer to have the deviations rectified at the cost of the second party.

9. Duties and responsibilities of the second party

9.1 The second party shall:

- a) take up the works and arrange for its completion within the time period stipulated in Clause 5;
- b) employ suitable skilled persons to carry out the works;
- c) regularly supervise and monitor the progress of work;
- d) abide by the technical suggestions/direction of supervisory personnel including engineers etc. regarding building construction;
- e) be responsible for bringing any discrepancy to the notice of the representative of the first party and seek necessary clarification;
- f) ensure that the work is carried out in accordance with specifications, drawings and within the total of the contract amount without any cost escalation;
- g) keep the first party informed about the progress of work;
- h) be responsible for all security and watch and ward arrangements at site till handing over of the building to the first party; and
- i) maintain necessary insurance against loss of materials/cash, etc. or workman disability compensation claims of the personnel deployed on the works as well as third party claims.
- j) Pay all duties, taxes and other levies payable by construction agencies as per law under the contract (First party will effect deduction (TDS) from running bills in respect of such taxes as may be imposed under the law).

10. Variations / Extra Items

The works shall be carried out by the second party in accordance with the approved drawings and specifications. However, if, on account of site conditions or any other factors, variations are considered necessary, the following procedure shall be followed:-

- a) The second party shall provide the Engineer with a quotation for carrying out the Variation when requested to do so by the Engineer. The Engineer shall assess the quotation, which shall be given within seven days of the request before the Variation is ordered.
- b) If the quotation given by the second party is unreasonable, the Engineer may order the Variation and make a change to the Contract Price which shall be based on Engineer's own forecast of the effects of the Variation on the Contractor's costs.

- c) The second party shall not be entitled to additional payment for costs which could have been avoided by giving early warning.

11. Securities

The Performance Security (Bank Guarantee from a Nationalized or Scheduled Bank in India in the format attached) shall be provided to the Employer no later than the date specified in the Letter of Acceptance and shall be issued in an amount and form and by a bank or surety acceptable to the Employer. The Performance Security shall be valid until a date 28 days from the date of issue of the Certificate of Completion in the case of a Bank Guarantee.

12. Termination

12.1 The Employer may terminate the Contract if the other party causes a fundamental breach of the Contract.

12.2 Fundamental breaches of Contract include, but shall not be limited to the following:

- (a) the contractor stops work for 28 days and the stoppage has not been authorized by the Engineer;
- (b) the Contractor has become bankrupt or goes into liquidation other than for a reconstruction or amalgamation;
- (c) the Engineer gives Notice that failure to correct a particular Defect is a fundamental breach of Contract and the Contractor fails to correct it within a reasonable period of time determined by the Engineer;
- (d) the Contractor does not maintain a security which is required;
- (e) the Contractor has delayed the completion of the Works by the number of days for which the maximum amount of liquidated damages can be paid, as defined in the Clause 7 of this agreement

12.3 Notwithstanding the above, the Employer may terminate the Contract for convenience.

12.4 If the Contract is terminated the Contractor shall stop work immediately, make the Site safe and secure, and leave the Site as soon as reasonably possible.

13. Payment upon Termination

13.1 If the Contract is terminated because of a fundamental breach of Contract by the Contractor, the Engineer shall issue a certificate for the value of the work done less advance payments received up to the date of the issue of the certificate, less other recoveries due in terms of the contract, less taxes due to be deducted at source as per applicable law.

13.2 If the Contract is terminated at the Employer’s convenience, the Engineer shall issue a certificate for the value of the work done, the reasonable cost of removal of Equipment, repatriation of the Contractor’s personnel employed solely on the Works, and the Contractor’s costs of protecting and securing the Works and less advance payments received up to the date of the certificate, less other recoveries due in terms of the contract and less taxes due to be deducted at source as per applicable law.

14. Dispute settlement

If over the works, any dispute arises between the two parties, relating to any aspects of this Agreement, the parties shall first attempt to settle the dispute through mutual and amicable consultation.

In the event of agreement not being reached, the matter will be referred for arbitration by a Sole Arbitrator not below the level of retired Superintending Engineer, PWD to be appointed by the first party. The Arbitration will be conducted in accordance with the Arbitration and Conciliation Act, 1996. The decision of the Arbitrator shall be final and binding on both the parties. The Arbitrator shall give his award/decision within 60 days of start of proceedings.

The Priced Bill of Quantities (Annexure 1), Format of Certificate (Annexure 2) and Specification and Drawings (Annexure 3) are attached.

Signed and delivered by Sri. _____ for and on behalf of the Contractor

In the presence of the Witness:

- i)
- ii)

SIGNATURE

Signed and delivered by Sri _____ Deputy Executive Engineer/Executive Engineer/Superintending Engineer _____ of _____ for an on behalf of the Government.

In the presence of the Witness:

- i)
- ii)

SIGNATURE

BILL OF QUANTITIES

The approximate Bill of Quantities is indicated below to give an idea of the work which should be executed in accordance with the approved drawings and specifications to enable the bidder to furnish the lump sum price. Bidders may, however, note that no variations in the lump sum cost is acceptable (except where extra items are ordered by the Engineer).

NAME OF PROJECT :- FRUITS AND VEGETABLE PROCESSING UNIT, KARBI ANGLONG, ASSAM						
CIVIL ESTIMATE						
Item No	Item Description	Unit	Qty	Rate in INR		Amount
				In Figure	In words	
(A)	SCHEDULE -1 EARTHWORK IN EXCAVATION					
1	Earth work in excavation by mechanical means (Hydraulic excavator) / manual means in foundation trenches or drains (not exceeding 1.5 m in width or 10 sqm on plan), including dressing of sides and ramming of bottoms, lift upto 1.5 m, including getting out the excavated soil and disposal of surplus excavated soil as directed, within a lead of 50 m.					
2	All Kinds of Soil	Cum	175			
3	Excavating, supplying and filling of local earth (including royalty) by mechanical transport upto a lead of 5km also including ramming and width or 10 sqm on plan), including dressing of sides and ramming of bottoms, lift upto 1.5 m, including getting out the excavated soil and disposal of surplus excavated soil as directed, within a lead of 50 m.					
	All Kinds of Soil	Cum	170			
	POST CONSTRUCTION ANTI - TERMITE TREATMENT					
4	Supplying chemical emulsion in sealed containers including delivery as specified.					
5	Chlorpyriphos/ Lindane emulsifiable concentrate of 20%	Litre	165			
6	Diluting and injecting chemical emulsion for POST-CONSTRUCTIONAL anti termite treatment (excluding the cost of chemical emulsion) : Along external wall where the apron is not provided using chemical emulsion @ 7.5 litres / sqm of the vertical surface of the substructure to a depth of 300mm including excavation channel along the wall & odding etc. complete:					
	With Chlorpyriphos/ Lindane E.C. 20% with 1% concentration	metre	22.00			

7	Treatment of soil under existing floors using chemical emulsion @ one litre per hole, 300 mm apart including drilling 12 mm diameter holes and plugging with cement mortar 1 :2 (1 cement : 2 Coarse sand) to match the existing floor:					
8	With Chlorpyriphos/Lindane E.C. 20% with 1% concentration	Sqm	22.00			
(B)	SCHEDULE - 2 PLAIN CEMENT CONCRETE WORKS					
1	Providing and laying in position cement concrete of specified grade excluding the cost of cantering and shuttering - All work up to plinth level :					
2	1:4:8 (1 Cement : 4 coarse sand (zone-III) derived from natural sources : 8 graded stone aggregate 40 mm nominal size derived from natural sources)	cum	24			
3	Providing and laying damp-proof course 50mm thick with cement concrete 1:2:4 (1 cement : 2 coarse sand (zone-III) derived from natural sources : 4 graded stone aggregate 20mm nominal size derived from natural sources).	Sqm	29.00			
(C)	SCHEDULE - 3 REINFORCED CEMENT CONCRETE WORKS					
1	Providing and laying in position specified grade of reinforced cement concrete, excluding the cost of centering, shuttering, finishing and reinforcement - All work up to plinth level :					
2	1:1.5:3 (1 cement : 1.5 coarse sand (zone-III) derived from natural sources : 3 graded stone aggregate 20 mm nominal size derived from natural sources)	cum	37.00			
3	Reinforced cement concrete work in walls (any thickness), including attached pilasters, buttresses, plinth and string courses, fillets, columns, pillars, piers, abutments, posts and struts etc. above plinth level up to floor five level, excluding cost of centering, shuttering, finishing and reinforcement :					
4	1:1.5:3 (1 cement : 1.5 coarse sand(zone-III) derived from natural sources : 3 graded stone aggregate 20 mm nominal size derived from natural sources)	cum	12.97			
5	Reinforced cement concrete work in beams, suspended floors, roofshaving slope up to 15° landings, balconies, shelves, chajjas, lintels,bands, plain window sills, staircases and spiral stair cases above plinth level up to floor five level, excluding the cost of centering, shuttering, finishing and reinforcement with 1:1.5:3 (1 cement : 1.5 coarse sand(zone-III) derived from natural sources : 3 graded stone aggregate 20 mm nominal size derived from natural sources).	cum	5.03			
	REINFORCEMENT					

1	Steel reinforcement for R.C.C. work including straightening, cutting, bending, placing in position and binding all complete upto plinth level and above plinth level					
2	Thermo-Mechanically Treated bars of grade Fe-500D or more.					
A	Substructure works	kg	2850			
B	Superstructure works	kg	1900			
C	RCC Flooring works	kg	1350			
(D)	SCHEDULE - 4 SHUTTERING (FORMWORK)					
1	Centering and shuttering including, strutting, propping, and removal of work for:					
2	Foundations, footings, bases for columns	Sqm	94.00			
3	Centering and shuttering including strutting, propping etc. and removal of form for					
4	Lintels, beams, plinth beams, girders, bressumers and cantilevers	Sqm	152.00			
5	Columns, piers, abutments, pillars, posts and struts	Sqm	111			
(E)	SCHEDULE - 5 BRICKWORK					
1	Brick work with common burnt clay modular bricks of class designation 7.5 in foundation and plinth in:					
2	Cement mortar 1:4 (1 cement : 4 coarse sand)	Cum	18			
3	Half brick masonry with common burnt clay F.P.S. (non modular) bricks of class designation 7.5 in superstructure above plinth level up to floor V level. Cement mortar 1:4 (1 cement :4 coarse sand)	Sqm	139			
(F)	SCHEDULE-6 CEMENT CONCRETE FLOORING					
1	Construction of granular sub-base by providing well graded material, spreading in uniform layers with motor grader on prepared surface, mixing by mix in place method with rotavator at OMC, and compacting with smooth wheel roller to achieve the desired density, complete as per Technical Specification Clause 401.					
	For Grading II Material	Cum	24.00			

2	Providing and laying in position ready mixed or site batched design mix cement concrete for reinforced cement concrete work; using coarse aggregate and fine aggregate derived from natural sources, Portland Pozzolana / Ordinary Portland /Portland Slag cement, admixtures in recommended proportions as per IS: 9103 to accelerate / retard setting of concrete, to improve durability and workability without impairing strength; including pumping of concrete to site of laying, curing, carriage for all leads; but excluding the cost of centering, shuttering, finishing and reinforcement as per direction of the engineer-in-charge; for the following grades of concrete. Note: Extra cement up to 10% of the minimum specified cement content in design mix shall be payable separately. In case the cement content in design mix is more than 110% of the specified minimum cement content, the contractor shall have discretion to either re-design the mix or bear the cost of extra cement.					
3	Concrete of M25 grade with minimum cement content of 330 kg /cum	cum	19.00			
(G)	SCHEDULE-7 PLASTERING					
1	12 mm thick Cement plaster of mix.					
2	1:4 (1 cement: 4 fine sand)	Sqm	411			
3	15 mm cement plaster on rough side of single or half brick wall of mix:					
4	1:4 (1 cement: 4 coarse sand)	Sqm	72			
	PAINTINGS:					
5.00	Providing and applying white cement based putty of average thickness 1 mm, of approved brand and manufacturer, over the plastered wall surface to prepare the surface even and smooth complete.	Sqm	483			
6	Wall painting with premium acrylic emulsion paint of interior grade, having VOC (Volatile Organic Compound) content less than 50 grams/ litre of approved brand and manufacture, including applying additional coats wherever required to achieve even shade and colour. (two coats)	Sqm	482			
7	With ready mixed red oxide zinc chromate primer of approved brand and manufacture on steel galvanised iron/steel works	Sqm	139			
8	Painting on G.S. sheet/Steel surface with synthetic enamel paint of approved brand and manufacture of required colour to give an even shade : Old Work (One or more coats)	Sqm	100			
9	Making plinth protection 50mm thick of cement concrete 1:3:6 (1 cement : 3 coarse sand (zone-III) derived from natural sources : 6 graded stone aggregate 20 mm nominal size derived from natural sources) over 75mm thick bed of dry brick ballast 40 mm nominal size, well rammed and consolidated and grouted with fine sand, including necessary excavation, levelling & dressing & finishing the top smooth.	Sqm	22.00			
(H)	SCHEDULE-8 STEEL WORKS					

1	Structural steel work in single section, fixed with or without connecting plate, including cutting, hoisting, fixing in position and applying a priming coat of approved steel primer all complete.	Kg	3491.88			
2	Structural steel work riveted, bolted or welded in built up sections, trusses and framed work, including cutting, hoisting, fixing in position and applying a priming coat of approved steel primer all complete.	Kg	2213.86			
3	Providing and fixing precoated galvanised iron profile sheets (size, shape and pitch of corrugation as approved by Engineer-in-charge) 0.50 mm (+ 0.05 %) total coated thickness with zinc coating 120 grams per sqm as per IS: 277, in 240 mpa steel grade, 5-7 microns epoxy primer on both side of the sheet and polyester top coat 15-18 microns. Sheet should have protective guard film of 25 microns minimum to avoid scratches during transportation and should be supplied in single length upto 12 metre or as desired by Engineerin-In- charge. The sheet shall be fixed using self drilling /self tapping screws of size (5.5x 55 mm) with EPDM seal, complete upto any pitch in horizontal/ vertical or curved surfaces, excluding the cost of purlins, rafters and trusses and including cutting to size and shape wherever required.					
A	For outer wall cladding	Sqm	133			
B	For Roofing work	Sqm	185			
1	Providing and fixing precoated galvanised steel sheet roofing accessories 0.50 mm (+0.05 %) total coated thickness, Zinc coating 120 grams per sqm as per IS: 277, in 240 mpa steel grade, 5-7 microns epoxy primer on both side of the sheet and polyester top coat 15-18 microns using self drilling/ self tapping screws complete :					
2	Ridges plain (500 - 600mm)	metre	18.00			
3	Flashings/ Aprons.(Upto 600 mm)	metre	10.00			
4	Gutter (600 mm over all girth)	metre	36.00			
5	Barge board (Upto 300 mm)	metre	25.00			
(I)	SCHEDULE - 9 TURBO VENTILATOR					
	Supplying, fitting and fixing in position turbo ventilator of Nylon made Typhonic bearing, double top cap ensured permanent alignment in inverted cap design, corrugated foil framed of aluminium fabrication for wind driven having wind velocity 1950 exhauster of effective throatal Dia 24 inch and overall Dia of 31 inch having over all height 19 inch as specified and directed by the Engineer- In- Charge, all complete	nos	4.00			
	FLOORING					
1	TILES WORKS					
2	CERAMIC TILES					
B)	ON WALLS					

1	Providing and fixing 1st quality ceramic glazed wall tiles conforming to IS: 15622 (thickness to be specified by the manufacturer), of approved make, in all colours, shades except burgundy, bottle green, black of any size as approved by Engineer-in-Charge, in skirting, risers of steps and dados, over 12 mm thick bed of cement mortar 1:3 (1 cement : 3 coarse sand) and jointing with grey cement slurry @ 3.3kg per sqm, including pointing in white cement mixed with pigment of matching shade complete	Sq.m	43			
	ON FLOOR					
(A)	CERAMIC					
1	Crazy ceramic tile flooring, with under layer 12 mm thick cement mortar 1:4 (1 cement: 4 coarse sand), with joints not exceeding 5 mm, including filling the gaps with ordinary cement mixture & mixing with synthetic polyester fibre, triangular in shape having specific gravity of 1.34 to 1.40, cross section size ranging from 10 to 40 micron & length upto 6 mm , mixing fibre @ 125 grams per 50 kg of cement in cement mortar, including providing and mixing water proofing material in mortar @ 1 kg per 50 kg of cement, all complete as per direction of Engineer-in-charge.	Sq.m	7			
(J)	SCHEDULE-10 FALSE CEILING					
	GYPSUM CEILING					
1	Providing and fixing false ceiling at all heights with integral densified calcium silicate reinforced with fibre and natural filler false ceiling tiles of Size 595x595mm of approved texture, design and patterns as per CPWD Specification 2019, to be laid in true horizontal level suspended on inter-locking metal T-Grid of hot dipped galvanised iron section of 0.33mmthick (galvanized @ 120 grams per sqm including both sides)comprising of main-T runners of size 24x38 mm of length 3000 mm,cross - T of size 24x32 mm of length 1200 mm and secondaryintermediate cross-T of size 24x32 mm of length 600mm to formgrid module of size 600 x 600 mm, suspended from ceiling usinggalvanised mild steel items (galvanizing @ 80 grams per sqm) i.e. 12x50 mm long dash fasteners, 6 mm dia fully threaded hanger rod upto 1000 mm length and L-shape level adjuster of size 76x25x25x1.6 mm fixed with grid and Z cleat of size 25x37x25x1.6mm thick with precut hole on both 25mm flange to pierce into 12x50mm or even bigger size dash fastener if require, fixed with Glavanised iron perimeter wall angle or size 24x24x0.40 mm of length 3000 mm to be fixed on periphery wall / partition with the help of plastic rawl plugs at 450mm center to center and 40 mm long dry wall S.S screws. The workshall be carried out as per specifications, drawing and as per directionsof the Engineer-inCharge.					
2	With 15 mm thick Tegular edged light weight calcium sliciate false ceiling tiles	Sq.m	21			
(J)	SCHEDULE-10 DOORS & WINDOW					

1	Providing and fixing panelled or panelled and glazed shutters for doors, windows and clerestory windows, fixing with butt hinges of required size with necessary screws, excluding panelling which will be paid for separately, all complete as per direction of Engineer-in-charge. (Note:- Butt hinges and necessary screws shall be paid separately)					
2	Second class teak wood					
3	35 mm thick shutters	Sq.m.	18.00			
4	Providing wood work in frames of doors, windows, clerestory windows and other frames, wrought framed and fixed in position with hold fast lugs or with dash fasteners of required dia & length (hold fast lugs or dash fastener shall be paid for separately).					
5	Sal wood	Cum	0.57			
6	Providing and fixing aluminium work for doors, windows, ventilators and partitions with extruded built up standard tubular sections/ appropriate Z sections and other sections of approved make conforming to IS: 733 and IS: 1285, fixing with dash fasteners of required dia and size, including necessary filling up the gaps at junctions, i.e. at top, bottom and sides with required EPDM rubber/ neoprene gasket etc. Aluminium sections shall be smooth, rust free, straight, mitred and jointed mechanically wherever required including cleat angle, Aluminium snap beading for glazing / paneling, C.P. brass / stainless steel screws, all complete as per architectural drawings and the directions of Engineer-in-charge. (Glazing, paneling and dash fasteners to be paid for separately) :					
7	For Fixed portion : Powder coated aluminium (minimum thickness of powder coating 50 micron)	kg	97.2			
8	For shutters of doors, windows & ventilators including providing and fixing hinges/ pivots and making provision for fixing of fittings wherever required including the cost of EPDM rubber / neoprene gasket required (Fittings shall be paid for separately)					
9	Powder coated aluminium (minimum thickness of powder coating 50 micron)	kg	97.2			
10	Providing and fixing glazing in aluminium door, window, ventilator shutters and partitions etc. with EPDM rubber / neoprene gasket etc. complete as per the architectural drawings and the directions of engineer-in-charge .					
11	With float glass panes of 5 mm thickness (weight not less than 12.50 kg/sqm)	Sqm	32.4			
12	Dash hold fastener 12.5 mm dia, 50 mm long with 6 mm dia bolt	each	100			
13.0	Filling the gap in between aluminium frame & adjacent RCC/ Brick/ Stone work by providing weather silicon sealant over backer rod of approved quality as per architectural drawings and direction of Engineer-in-charge complete.					
14.00	Upto 5mm depth and 5 mm width	rmt	50			

15	Supplying and fixing rolling shutters of approved make, made of required size M.S. laths, interlocked together through their entire length and jointed together at the end by end locks, mounted on specially designed pipe shaft with brackets, side guides and arrangements for inside and outside locking with push and pull operation complete, including the cost of providing and fixing necessary 27.5 cm long wire springs manufactured from high tensile steel wire of adequate strength conforming to IS: 4454 - part 1 and M.S. top cover of required thickness for rolling shutters.					
16	80x1.25 mm M.S. laths with 1.25 mm thick top cover	Sq.m.	18			
17	Providing and fixing ball bearing for rolling shutters.	each	2			
18	Extra for providing mechanical device chain and crank operation for operating rolling shutters. Exceeding 10.00 sqm and upto 16.80 sqm in the area	Sq.m.	18			
	ALUMINIUM FITTINGS					
1	Providing and fixing aluminium sliding door bolts, ISI marked anodised (anodic coating not less than grade AC 10 as per IS : 1868), transparent or dyed to required colour or shade, with nuts and screws etc. complete :					
2	250mm x 16mm	Each	7			
3	Providing and fixing aluminium tower bolts, ISI marked, anodised (anodic coating not less than grade AC 10 as per IS : 1868) transparent or dyed to required colour or shade, with necessary screws etc. complete					
4	Tower bolts					
	250x10 mm	Each	7			
5	Providing and fixing aluminium handles, ISI marked, anodised (anodic coating not less than grade AC 10 as per IS : 1868) transparent or dyed to required colour or shade, with necessary screws etc. complete :					
6	125 mm	Each	7			
7	Providing and fixing ISI marked aluminium butt hinges anodised (anodic coating not less than grade AC 10 as per IS: 1868) transparent or dyed to required colour or shade with necessary screws etc. complete:					
8	100x75x4 mm	Each	28			
	Total					

NAME OF PROJECT :- FRUITS AND VEGETABLE PROCESSING UNIT, KARBI ANGLONG, ASSAM

CIVIL ESTIMATE - BOUNDARY WALL

Item No	Item Description	Unit	Qty	Rate in INR		Amount
				In Figure	In Words	
(A)	Description of Items					
1	Fencing with angle iron post placed at required distance embedded in cement concrete blocks, every 15th post, last but one end post and corner post shall be strutted on both sides and end post on one side only and provided with horizontal lines and two diagonals interwoven with horizontal wires, of barbed wire weighing 9.38 kg per 100 m (minimum), between the two posts fitted and fixed with G.I. staples, turn buckles etc. complete. (Cost of posts, struts, earth work and concrete work to be paid for separately). Payment to be made per metre cost of total length of barbed wire used.					
2	With G.I. barbed wire	RM	840.00			
3	Supplying at site Angle iron post & strut of required size including bottom to be split and bent at right angle in opposite direction for 10 cm length and drilling holes upto 10 mm dia. etc. complete.(75x5x5)	kg	1244.88			
4	Earth work in surface excavation not exceeding 30 cm in depth but exceeding 1.5 m in width as well as 10 sqm on plan including getting out and disposal of excavated earth upto 50 m and lift upto 1.5 m, as directed by Engineer-in- Charge					
	All Kinda of Soil	Cum	4.536			
5	Providing and laying in position cement concrete of specified grade excluding the cost of cantering and shuttering - All work up to plinth level :					
	In prop 1cement: 4 sand :8 coarse aggregate by volume	cum	4.536			
	Total					

NAME OF PROJECT :- CONSTRUCTION OF FRUITS AND VEGETABLE PROCESSING UNIT,AT AMBINONG, WEST KARBI ANGLONG.

CIVIL ESTIMATE – STORM WATER DRAIN

Item No	Items Description	Unit	Qty	Rate in INR		Amount
				In figure	In words	
(A)	SCHEDULE -1 EARTHWORK IN EXCAVATION					
1						
	Earth work in excavation by mechanical means (Hydraulic excavator) /manual means in foundation trenches or drains (not exceeding 1.5 m in width or 10 sqm on plan), including dressing of sides and ramming of bottoms, lift upto 1.5 m, including getting out the excavated soil and disposal of surplus excavated soil as directed, within a lead of 50 m.					
2	All Kinda of Soil	Cum	42.00			
(B)	SCHEDULE - 2 PLAIN CEMENT CONCRETE WORKS					
1	Providing and laying in position cement concrete of specified grade excluding the cost of cantering and shuttering - All work up to plinth level :					
2	1:4:8 (1 Cement : 4 coarse sand (zone-III) derived from natural sources : 8 graded stone aggregate 40 mm nominal size derived from natural sources)	cum	7.00			
(D)	SCHEDULE - 4 PLYBOARD SHUTTERING (FORMWORK)					
1	Centering and shuttering including, strutting, propping, and removal of work for:					
	Columns, Pillars, Posts & Strut of square/ rectangular/ polygonal in plan or any shape like Tee/L etc. having plane vertical face	Sqm	68.00			
	Column, Foundation, Footings, bases for column					
(E)	BRICKWORK					
1	Brick work in cement mortar with 1st class brick including racking out joints and curing complete as directed.					
	In superstructure above plinth level up to 1st floor level.					
	In proportion 1:4.(1 cement:4 sand)	Cum	10.00			
(F)	SCHEDULE-7 PLASTERING					
1	15 mm thick Cement plaster in single coat on single or half brick wall for interior plastering up to 1st floor level including arises, internal rounded angles, not exceeding 80mm girth and finished even and smooth including curing complete as directed.					
	a) In cement mortar 1:4	Sqm	110.00			

ESTIMATE OF INTERNAL ROAD OF FRUITS AND VEGETABLE PROCESSING UNIT

INTERNAL ROAD

Item No	Items Description	Unit	Qty	Rate in INR		Amount
				In figure	In words	
	Excavation					
1	Excavation for roadway in soil using manual means for carrying of cut earth to embankment site with a lift upto 1.5 m and lead upto 50 m as per Technical Specification Clause 302.3 (Manual method should be adopted where machines can not be deployed due to site condition)	cum	67.5			
	In ordinary Soil					
2	GSB (GRANULAR SUB-BASES, BASES (NON-BITUMINOUS) AND SHOULDERS). Granular Sub-base with Well Graded Material (Table 400.1)					
	Construction of granular sub-base by providing well graded material, spreading in uniform layers with motor grader on prepared surface, mixing by mix in place method with rotavator at OMC, and compacting with smooth wheel roller to achieve the desired density, complete as per Technical Specification Clause 401.					
	For Grading II Material	cum	25.3125			
	PCC					
3	Providing and laying in position cement concrete of specified grade excluding the cost of cantering and shuttering - All work up to plinth level :					
4	1:4:8 (1 Cement : 4 coarse sand (zone-III) derived from natural sources : 8 graded stone aggregate 40 mm nominal size derived from natural sources)	cum	16.875			
	SAND FILLING					
5	Supplying and filling in plinth with sand under floors, including watering, ramming, consolidating and dressing complete.	cum	6.75			
	CC PAVER BLOCK					
6	Interlocking concrete Block pavement with edge block (i) Providing and lying interlocking concrete pavement block (M40) having thickness 80 mm as per technical specification clause 1504 (including edge) Block/Edge restraints)					
			168.75			
	Total					

NAME OF PROJECT :- CONSTRUCTION OF FRUITS AND VEGETABLE PROCESSING UNIT,AT AMBINONG, WEST KARBI ANGLONG.						
SH: Internal Electrical						
Item No.	Items Description	Unit	Quantity	Rate in INR		Amount
				In figure	In words	
2	WIRING IN PVC CONDUIT					
2	Wiring for light point/ fan point/ exhaust fan point/ call bell point with 1.5 sq.mm FRLS PVC insulated copper conductor single core cable in surface/recessed medium class PVC conduit, with modular switch, modular plate, suitable GI box and earthing the point with 1.5 sq.mm FRLS PVC insulated copper conductor single core cable etc. as required.					
3	Group A	Point	10			
4	Group B	Point	10			
5	Group C	Point	10			
6	Wiring for twin control light point with 1.5 sq.mm FRLS PVC insulated copper conductor single core cable in surface / recessed medium class PVC conduit, 2 way modular switch, modular plate, suitable GI box and earthing the point with 1.5 sq.mm FRLS PVC insulated copper conductor single core cable etc. as required.	Point	8			
7	Wiring for light/ power plug with 2X4 sq. mm FRLS PVC insulated copper conductor single core cable in surface/ recessed medium class PVC conduit along with 1 No. 4 sq. mm FRLS PVC insulated copper conductor single core cable for loop earthing as required.	Meter	120			
8	Wiring for light/ power plug with 4X4 sq. mm FRLS PVC insulated copper conductor single core cable in surface/ recessed medium class PVC conduit along with 2 Nos. 4 sq. mm FRLS PVC insulated copper conductor single core cable for loop earthing as required.	Meter	50			
9	Wiring for circuit/ sub main wiring along with earth wire with the following sizes of FRLS PVC insulated copper conductor, single core cable in surface/ recessed medium class PVC conduit as required.					
10	2 X 1.5 sq. mm + 1 X 1.5 sq. mm earth wire	Meter	50			
11	2 X 2.5 sq. mm + 1 X 2.5 sq. mm earth wire	Meter	40			
12	2 X 6 sq. mm + 1 X 6 sq. mm earth wire	Meter	50			
13	2 X 10 sq. mm +1 X6 Sq. mm earth	Meter	20			
14	4 X 10 sq. mm +2 X6 Sq. mm earth	Meter	80			
15	4 X 16 sq. mm +2 X6 Sq. mm earth	Meter	50			

15	Supplying and drawing co-axial TV cable RG-6 grade, 0.7 mm solid copper conductor PE insulated, shielded with fine tinned copper braid and protected with PVC sheath in the existing surface/ recessed steel/ PVC conduit as required.	Meter	100			
16	Supplying and fixing of following sizes of medium class PVC conduit along with accessories in surface/recess including cutting the wall and making good the same in case of recessed conduit as required. 20 mm					
17	25 mm	Meter	100			
18	Supplying and fixing following modular switch/ socket on the existing modular plate & switch box including connections but excluding modular plate etc. as required.					
19	5/6 A switch	Each	20			
20	2 way 5/6 A switch	Each	10			
21	15/16 A switch	Each	20			
22	3 pin 5/6 A socket outlet	Each	10			
23	6 pin 15/16 A socket outlet	Each	10			
24	Telephone socket outlet	Each	4			
25	TV antenna socket outlet	Each	2			
26	Bell push	Each	2			
27	Supplying and fixing two module stepped type electronic fan regulator on the existing modular plate switch box including connections but excluding modular plate etc. as required.	Each	10			
28	Supplying and fixing modular blanking plate on the existing modular plate & switch box excluding modular plate as required.	Each	20			
29	Supplying and fixing following size/ modules, GI box along with modular base & cover plate for modular switches in recess etc. as required.					
30	1 or 2 Module (75mmX75mm)	Each	4			
31	3 Module (100mmX75mm)	Each	4			
32	4 Module (125mmX75mm)	Each	4			
33	6 Module (200mmX75mm)	Each	4			
34	8 Module (125mmX125mm)	Each	1			
35	12 Module (200mmX150mm)	Each	1			
36	Supplying and fixing following Modular base & cover plate on existing modular metal boxes etc. as required.					
37	1 or 2 Module	Each	4			
38	3 Module	Each	2			
39	4 Module	Each	2			
40	6 Module	Each	2			

41	8 Module	Each	1			
41	12 Module	Each	1			
42	Supplying and fixing suitable size GI box with modular plate and cover in front on surface or in recess, including providing and fixing 3 pin 5/6 A modular socket outlet and 5/6 A modular switch, connections etc. as required.	Each	5			
43	Supplying and fixing suitable size GI box with modular plate and cover in front on surface or in recess, including providing and fixing 6 pin 5/6 & 15/16 A modular socket outlet and 15/16 A modular switch, connections etc. as required.	Each	20			
44	Supplying and fixing 3 pin, 5 A ceiling rose on the existing junction box/wooden block including connections etc, as required	Each	10			
	INSTALLATION OF FIXTURES & FANS					
45	Installation ,Testing, Commissioning of wall bracket /ceiling fittings of all sizes and shapes containing up to two GLS/CFL/LED lamps per fitting, complete with all accessories including connections etc. as required.	Each	30			
46	Supplying and fixing call bell/ buzzer suitable for single phase, 230 V, complete as required.	Each	4			
47	Providing and fixing plain 16/0.20mm (0.50sqmm) twin flat flexible, FRLS PVC insulated, copper conductor cable, in PVC sleeve of suitable size on the floor/ wall, or side of the table/ door etc. as required.	Meter	110			
48	Installation, testing and commissioning of ceiling fan, including wiring the down rods of standard length (up to 30 cm) with 1.5 sq. mm FRLS PVC insulated, copper conductor, single core cable, including providing and fixing phenolic laminated sheet cover on the fan box etc. as required.	Each	8			
	CONDUITING & WIRING OF T.V. , TELEPHONE and LAN SYSTEM					
49	Supplying and drawing following pair 0.5 sq. mm FR PVC insulated annealed copper conductor, unarmored telephone cable in the existing surface/ recessed steel/ PVC conduit as required.					
50	2 Pair	Meter	100.00			
51	Supplying and fixing of following sizes of medium class PVC conduit along with accessories in surface/recess including cutting the wall and making good the same in case of recessed conduit as required.					
52	25mm dia conduit pipe	Meter	20.00			
53	32mm dia conduit pipe	Meter	20.00			
	MODULAR BOXES & SWITCH/SOCKETS					
54	Supplying and fixing suitable size GI box with modular plate and cover in front on surface or in recess, including providing and fixing 2 nos. 3 pin 5/6 A modular socket outlet and 2 nos. 5/6 A modular switch, connections etc. as required. (For light plugs to be used in non residential buildings).	Each	20			
	CHAPTER-2-MCCB, MCB & DB'S					

55	Providing and fixing following rating and breaking capacity and pole MCCB with THERMOMAGNETIC RELEASE AND TERMINAL spreaders in existing cubicle panel board including drilling holes in cubicle panel, making connections, etc. as required.					
56	125 A,36KA,FPMCCB	Each	5			
57	Providing and fixing following capacity TP&N dconnector fuse switch unit inside the existing panel board with ISI marked HRC fuses including drilling holes in cubicle panel, making connections, etc. as required.					
58	63 A,36KA,FPMCCB	Each	5			
59	Supplying and fixing following way, horizontal type three pole and neutral, sheet steel, MCB distribution board, 415 V, on surface/ recess, complete with tinned copper bus bar, neutral bus bar, earth bar, din bar, interconnections, powder painted including earthing etc. as required but without MCB/RCCB/Isolator)					
60	4 way (4 + 12), Double door	Each	2			
61	8 way (4 + 24), Double door	Each	4			
62	Supplying and fixing of following ways surface/ recess mounting, vertical type, 415 V, TPN MCB distribution board of sheet steel, dust protected, duly powder painted, inclusive of 200 A tinned copper bus bar, common neutral link, earth bar, din bar for mounting MCBs (but without MCBs and incomer) as required . (Note : Vertical type MCB TPDB is normally used where 3 phase outlets are required.)					
63	4 way (4 + 12), Double door	Each	1			
64	8 way (4 + 24), Double door	Each	1			
65	Supplying and fixing 5 A to 32 A rating, 240/415 V, 10 kA, "C" curve, miniature circuit breaker suitable for inductive load of following poles in the existing MCB DB complete with connections, testing and commissioning etc. as required.					
66	Single pole	Each	24			
67	Triple pole	Each	3			
68	Supplying and fixing single pole blanking plate in the existing MCB DB complete etc. as required.	Each	10			
69	Supplying and fixing following rating, four pole, (three phase and neutral), 415 volts, residual current circuit breaker (RCCB), having a sensitivity current 30 Ma in the existing MCB DB complete with connections, testing and commissioning etc. as required.					
70	40 A	Each	4			
71	63 A	Each	4			
72	Supplying and fixing Cable End Box (Loose Wire Box) suitable for following triple pole and neutral, sheet steel, MCB distribution board, 415 Volts, on surface/ recess, complete with testing and commissioning etc.as required.					

73	For 4 way, Double door TPN MCBDB	Each	1			
74	For 8 way, Double door TPN MCBDB	Each	4			
75	Supplying and fixing Cable End Box (Loose Wire Box) suitable for triple pole and neutral, sheet steel, Vertical MCB distribution board, 415 Volts, on surface/ recess, complete with testing and commissioning etc. as required.	Each	4			
76	Earthing with G.I. earth pipe 4.5 metre long, 40 mm dia including accessories, and providing masonry enclosure with cover plate having locking arrangement and watering pipe etc. with charcoal/ coke and salt as required.	Each	2			
77	Earthing with G.I. earth plate 600 mm X 600 mm X 6 mm thick including accessories, and providing masonry enclosure with cover plate having locking arrangement and watering pipe of 2.7 metre long etc. with charcoal/ coke and salt as required.	Each	2			
78	Supplying and laying 6 SWG G.I. wire at 0.50 metre below ground level for conductor earth electrode, including connection/ termination with GI thimble etc. as required.	Metre	50			
79	Supplying and laying 25 mm X 5 mm copper strip at 0.50 metre below ground as strip earth electrode, including connection/ terminating with nut, bolt, spring, washer etc. as required. (Jointing shall be done by overlapping and with 2 sets of brass nut bolt & spring washer spaced at 50mm)	Metre	50			
80	Providing and fixing 25 mm X 5 mm G.I. strip on surface or in recess for connections etc. as required.	Metre	50			
81	Providing and fixing 4mm dia. copper wire on surface or in recess for loop earthing as required.	Metre	50			
	NON-SCHEDULE ITEM					
1	30 Watts - Panel Light Supply and fixing of 30 W LED Square Type Recessed Fitting with LED Fitting complete with electronic deiver with PVC Unsheathed copper leads from terminals to the fitting and as directed by Engineer incharge	Each	20			
2	Supply and fixing of 12 W LED round Type Recessed Fitting with LED Fitting complete with electronic deiver with PVC Unsheathed copper leads from terminals to the fitting and as directed by Engineer incharge	Each	10			
3	Supply and fixing of LED Tube Light with batten suitable for up to 1 X 22 watt LED tube light fitting including tube on Surface complete in all respect.cat-AA	Each	4			
4	supply and erection of AC 1400mm Sweep 230/250 Volts, 50 Hz ceiling with regulator standar down rod, blades including conection etc. complete as required.	Each	8			
5	Exhaust Fan Supply of AC 230/250 volts 50 HZ exhaust fans including providing bolts, mounting frame and cther accessories etc. complete as per the engineer incharge.	Each	2			

6	Supply with installation & commissioning of readymade maintenance free CPRI approved chemical earthing system with 50 mm dia. 3.00 Metres length corrosion free dual pipe technology G.I. CHEMRODE ELECTRODE complete with RESLOW Grounding Minerals (25 K and Advance Earth Pit cover (PV including excavation of earth pit and construction brick earth chamber including plastering both inner & outer surface of brick wall as specified and directed by the deptt.	Each	1			
7	MAIN PANEL					
MR	Design, manufacture, supply, installation, testing and commissioning of Main Panel (outdoor type) fabricated out of 14 SWG CRCA sheet steel, IP52, wall / floor mounting type. The sheet steel shall undergo minimum 9 tank treatment followed by finishing powder coating of min 60 micron thickness. the board includes 415 V electrolytic Aluminium Bus Bar, removable gland plates, cable glands, including connection with outgoing feeders complete in all respect.					
	12 Nos. outgoing feeders shall be provided with energy analyser / electronic dual reading KWHR meter with RS 485 communication port, CT's with accuracy class 1.					
	The incoming MCCB shall be microprocessor based with inbuilt O/L & S/C release with E/F protection and all Outgoings MCCB's shall be thermal-magnetic based with inbuilt O/L & S/C release.					
	The MCCB's shall be Ics = 100% Icu, with rotary handle & pad locking arrangement, with adjustable O/L & adjustable S/C trip setting as per load requirement. TP MCCB shall be with solid isolable neutral link. The breaking capacity specified is Ics value.					
	The above board shall be complete with 3 nos. phase indicating lights, flush mounted Ammeter, Voltmeter, CT's, PT's, selector switches, protective fuses etc. at Incomer with all inter connections by min. 2.5 sq.mm. Copper wires.					
	INCOMER : 250 AMP FP MCCB (25 KA)					
	BUS BAR : 250 AMP, 500 Volts, 3 phase 50 HZ TPN high conductivity electrolytic Aluminium bus bar of suitable length, insulated by heat shrinkable sleeves. The current density of bus bar shall be minimum 1.00 sq mm / amp.					
	The Maximum allowable temperature for the Bus bar to be restricted to 85 deg C. The temperature rise should be restricted to 35 deg C above ambient temperature.					
	OUT GOINGS :					
	12 Nos. 40, FP MCB, 10kA with ON/OFF indicating lamps.					
	4 Nos. 16A, DP MCB, 10kA with ON/OFF indicating lamps.	SET	1			

NAME OF PROJECT :- CONSTRUCTION OF FRUITS AND VEGETABLE PROCESSING UNIT,AT AMBINONG, WEST KARBI ANGLONG.

EXTERNAL LIGHTING

NON SCHEDULE ITEMS

Item No.	DESCRIPTION OF ITEMS	UNIT	QTY.	RATE in INR		AMOUNT
				In figure	In words	
1	SUB LT PANEL					
	Supplying, installation, testing & commissioning of cubical type LT panel suitable for 415 V, 3 Phase, 4 Wire 50 Hz AC supply system having fabricated in compartmentalized design from CRCA sheet steel of 2 mm thick for frame work and covers, 3 mm thick for gland, plates i/c cleaning & finishing complete with 7 tank process for powder coating in approved shade, having suitable Amp capacity extensible type TPN aluminium alloy bus bars of light conductivity, DMC / SMC bus bars of high conductivity, DMC/ SMC bus bar supports, with short circuit withstand capacity of 31 MVA for 1 Sec., bottom base channel of MS section not less than 100 mm x 50 mm x 5 mm thick, fabrication shall be done in transportable sections, entire panel shall have a common Aluminium/GI earth bar of size 25 mm x 5 mm at the rear with 2 Nos. earth stud, solid connections from main bus bar to switch gears with required size of Al. bus bars and control wiring with sq. mm. PVC insulated copper conductor S/C cable, cable alleys, cable gland plates in two half, i/c providing following switch gears :-					
A).	INCOMING SUPPLY :					
	1 No. 63 A, 4P (100% Neutral) MCCB (36 kA) with Microprocessor based O/L, S/C and E/F releases.					
B)	METERING & INDICATING LIGHTS					
	1 Nos MFM Meters					
	1 Set of 100/5A, CL-1, 15VA CTs for measuring.					
	Sets of phase indicating ,ON/OFF,TRIP Indicating lamps with 2A control MCBs.					
C)	BUSBAR:					
	Electrolytic high conductivity TPN (100% Neutral) Aluminium busbars rated at 200 amps (25 kA) with heat shrinkable PVC sleeves.					
D)	OUTGOING FEEDER:					
ii	2Nos.32 A TPN MCB with Timer for LANDSCAPING & EXT. POLE LIGHTS .					
iii	2Nos.32 A TPN MCB with Timer for LANDSCAPING & EXT. POLE LIGHTS .					
iv		Set	1			
2	CABLING WORK (SUPPLY)					
i).	Supply of following size of XLPE / PVC insulated,PVC Sheathed, Aluminium Conductor armoured power cable of 1.1kV grade etc. as required.					

d)	4C x 6sq.mm 1.1kV Al. Cable	MTR	80			
3A	LAYING OF CABLES :					
3B	Laying of one number XLPE / PVC insulated, PVC sheathed Aluminium Conductor Armoured power cable of 1.1kV grade of following sizes in ground including excavation and backfilling and identified at regular intervals as required.					
d)	4C x 6sq.mm 1.1kV Al. Cable	MTR	80			
4	LT CABLE TERMINATION					
	End termination with brass compression gland and aluminium lugs for following size of PVC insulated and PVC sheathed / XLPE aluminium conductor cable of 1.1 KV grade as required.					
d)	4C x 6sq.mm 1.1kV Al. Cable	Nos	8			
5	STREET LIGHT POLES 7 MTR Galvanised:					
	Supply , fixing, Testing & Commissioning of 7 mtr long, 3mm thick sheet, hot dip galvanised poles of bottom dia 130mm/70mm respectively with base plate dimensions 220X220X14 mm with galvanised Single Arm Bracket of 1.00 mtr length. The pole shall be Erected on a suitable size of Cement Concrete 1:2:4 foundation as per Manufacturers standards along with Grouting the Foundation Bolts, nuts and 1.5 mtr long, 50 mm dia suitably bend, GI, Medium Class Pipe for cable entry, suitable size Inbuilt Cable End Box opening approx. 600 mm above the Pole Base with 2 Nos. 6Way 15 Amp, Bakelite Connectors, 1 No 6 Amp, SP MCB C Curve etc as required. The door shall be vandal resistant and shall be weather proof to ensure safety of inside connections. The door shall be flush with the exterior surface and shall have suitable locking arrangement. There shall also be suitable arrangement for the purpose of earthing. The poles shall be complete with integral terminal boxes, MCB cut-outs, pole foundation bolts, lightning arrester, earthing, etc. as required. The poles shall have provisions for mounting and connecting an additional 250 Watt MH -type outdoor light fitting	nos.	6			
	Supply and fixing of LED Street light Fitting having die cast aluminium body and diffuser with driver set suitable for 30Watt. to 40 Watt. Confirming to IP 65 and above protection complete in all respect. CAT-AA	nos.	6			
6	EARTHING SYSTEM					
iii	Supplying and installation of following sizes of earth strip & wires by using spacer clamp for main earth flat, suitable clamping with M.S / Cu. flats for earthwires etc., including terminal crimping type sockets, bolts & washers, etc required for the complete job.					
d	Providing and fixing 6 SWG GI wire on surface are in race for loop earthing long with existing conduit / cable as required	MTR	100			

NAME OF PROJECT :- CONSTRUCTION OF FRUITS AND VEGETABLE PROCESSING UNIT, AT AMBINONG, WEST KARBI ANGLONG.

PLUMBING WORKS

Item no	Items Description	Unit	Qty.	Rate in INR		Amount
				In figure	In words	
A	INTERNAL WATER SUPPLY					
1	Providing and fixing Chlorinated Polyvinyl Chloride (CPVC) pipes, having thermal stability for hot & cold water supply, including all CPVC plain & brass threaded fittings, i/c fixing the pipe with clamps at 1.00 m spacing. This includes jointing of pipes & fittings with one step CPVC solvent cement and the cost of cutting chases and making good the same including testing of joints complete as per direction of Engineer in Charge.					
	Concealed work including cutting chases and making good the walls etc.					
2	15 mm nominal dia Pipes	Metre	20			
3	20mm nominal dia Pipes	Metre	20			
4	25mm nominal dia Pipes	Metre	15			
5	32mm nominal dia Pipes	Metre	10			
6	Constructing masonry Chamber 60x60x75 cm inside, in brick work in cement mortar 1:4 (1 cement : 4 coarse sand) for sluice valve, with C.I. surface box 100mm top diameter, 160 mm bottom diameter and 180 mm deep (inside) with chained lid and RCC top slab 1:2:4 mix (1 cement : 2 coarse sand : 4 graded stone aggregate 20mm nominal size) , i/c necessary excavation, foundation concrete 1:5:10 (1 cement : 5 fine sand : 10 graded stone aggregate 40 mm nominal size) and inside plastering with cement mortar 1:3 (1 cement : 3 coarse sand) 12 mm thick, finished with a floating coat of neat cement complete as per standard design :					
7	With common burnt clay F.P.S.(non modular) bricks of class designation 7.5	Each	2			
8	Providing and fixing enclosed type water meter (bulk type) conforming to IS : 2373 and tested by Municipal Board complete with bolts, nuts, rubber insertions etc. (The tail pieces if required will be paid separately) :					
9	80 mm dia nominal bore	Each	1			
	TOTAL					
B	EXTERNAL WATER SUPPLY (SCHEDULE ITEM)					
	Piping					
1	Providing and fixing Chlorinated Polyvinyl Chloride (CPVC) pipes, having thermal stability for hot & cold water supply including all CPVC plain & brass threaded fittings This includes jointing of pipes & fittings with one step CPVC solvent cement, trenching, refilling & testing of joints complete as per direction of Engineer in Charge.					

	External work					
2	15 mm nominal dia Pipes	Metre	70			
3	20 mm nominal dia Pipes	Metre	70			
4	25mm nominal dia Pipes	Metre	50			
5	32mm nominal dia Pipes	Metre	40			
6	40mm nominal dia Pipes	Metre	30			
	WATER TANK					
7	Providing and placing on terrace (at all floor levels) polyethylene water storage tank, IS : 12701 marked, with cover and suitable locking arrangement and making necessary holes for inlet, outlet and overflow pipes but without fittings and the base support for tank.					
	Sintex make	per litre	1500			
8	Providing & Fixing of Gun Metal fire Brigade Connection (inlet collection head) consisting of 63mm instantaneous type male coupling with built in check valves and 150 mm dia flanged outlet complete with bolts, nuts and rubber insertions as per IS:904-1983 complete as reqd. MAKE: ESSEL/WINCO/NEWAGE					
	b) 04 way	each	1			
	Down Take pipe					
	PVC PIPES,BENDS,JUNCTIONS,TEES ETC.					
9	Providing and fixing Chlorinated Polyvinyl Chloride (CPVC) pipes, having thermal stability for hot & cold water supply including all CPVC plain & brass threaded fittings This includes jointing of pipes & fittings with one step CPVC solvent cement, trenching, refilling & testing of joints complete as per direction of Engineer in Charge.					
10	(i) 150mm dia.	each	5			
11	(ii) 100mm dia.	each	5			
	SOAK PIT AND INSPECTION CHAMBER					

12	Constructing brick masonry chamber for underground C.I. inspection chamber and bends with bricks in cement mortar 1:4 (1 cement : 4 coarse sand) C.I. cover with frame (light duty) 455x610 mm internal dimensions, total weight of cover with frame to be not less than 38 kg (weight of cover 23 kg and weight of frame 15 kg), R.C.C. top slab with 1:1.5:3 mix (1 cement : 1.5 fine sand : 3 graded stone aggregate 20 mm nominal size), foundation concrete 1:5:10 (1 cement : 5 fine sand : 10 graded stone aggregate 40 mm nominal size), inside plastering 12 mm thick with cement mortar 1:3 (1 cement : 3 coarse sand), finished smooth with a floating coat of neat cement on walls and bed concrete etc. complete as per standard design:					
13	Inside dimensions 500x700 mm and 45 cm deep for pipe line with one or two inlets : With common burnt clay F.P.S. (non modular) bricks of class designation 7.5	each	4			
14	Making soak pit 2.5 m diameter 3.0 metre deep with 45 x 45 cm dry brick honey comb shaft with bricks and S.W. drain pipe 100 mm diameter, 1.8 m long complete as per standard design.					
15	With common burnt clay F.P.S. (non modular) bricks of class designation 7.5	each	2			
	TUBE WELL					
16	Boring/drilling bore well of required dia for casing/ strainer pipe, by suitable method prescribed in IS: 2800 (part I), including collecting samples from different strata, preparing and submitting strata chart/ bore log, including hire & running charges of all equipments, tools, plants & machineries required for the job, all complete as per direction of Engineer-in-charge, upto 90 metre depth below ground level.					
17	All types of soil : 300 mm dia	Metre	30			
18	Supplying, assembling, lowering and fixing in vertical position in bore well, ERW (Electric Resistance Welded) FE 410 mild steel screwed and socketed/plain ended casing pipes of required dia, conforming to IS: 4270, of reputed & approved make, including painted with outside surface with two coats of anticorrosive paint of approved brand and manufacture, including required hire & labour charges, fittings & accessories, all complete, for all depths, as per direction of Engineer-in-charge.					
19	200 mm nominal size dia having minimum wall thickness 5.40 mm	Metre	30			
20	Providing and fixing suitable size threaded mild steel cap or spot welded plate to the top of bore well housing/ casing pipe, removable as per requirement, all complete for borewell of:					
21	200 mm dia	each	2			
C	SEWERAGE (SCHEDULED ITEMS)					

22	Excavating trenches of required width for pipes, cables, etc including excavation for sockets, and dressing of sides, ramming of bottoms, depth upto 1.5 m, including getting out the excavated soil, and then returning the soil as required, in layers not exceeding 20 cm in depth, including consolidating each deposited layer by ramming, watering, etc. and disposing of surplus excavated soil as directed, within a lead of 50 m :					
23	All kinds of soil : Pipes, cables etc. exceeding 80 mm dia. But not exceeding 300 mm dia	Metre	30			
24	Constructing brick masonry manhole in cement mortar 1:4 (1 cement : 4 coarse sand) with R.C.C. top slab with 1:1.5:3 mix (1cement : 1.5 coarse sand (zone-III) : 3 graded stone aggregate 20 mm nominal size), foundation concrete 1:4:8 mix (1 cement : 4 coarse sand (zone-III) : 8 graded stone aggregate 40 mm nominal size), inside plastering 12 mm thick with cement mortar 1:3 (1 cement: 3 coarse sand) finished with floating coat of neat cement and making channels in cement concrete 1:2:4 (1 cement : 2 coarse sand : 4 graded stone aggregate 20 mm nominal size) finished with a floating coat of neat cement complete as per standard design :					
25	Inside size 90x80 cm and 45 cm deep including C.I. cover with frame (light duty) 455x610 mm internal dimensions, total weight of cover and frame to be not less than 38 kg (weight of cover 23 kg and weight of frame 15 kg) :					
26	With common burnt clay F.P.S. (non modular) bricks of class designation 7.5	each	3			
27	Extra for depth for manholes :					
28	Size 90x80 cm					
29	With common burnt clay F.P.S. (non modular) bricks of class designation 7.5	metre	2			
30	Providing, laying and jointing glazed stoneware pipes class SP-1 with stiff mixture of cement mortar in the proportion of 1:1 (1 cement : 1 fine sand) including testing of joints etc. complete :					
31	200 mm diameter	metre	50			
D	STORM WATER					
1	Excavating trenches of required width for pipes, cables, etc, including excavation for sockets, depth upto 1.5 m, including getting out the excavated materials, returning the soil as required in layers not exceeding 20 cm in depth, including consolidating each deposited layers by ramming, watering etc., stacking serviceable material for measurements and disposal of unserviceable material as directed, within a lead of 50 m : All kinds of soil					
2	Pipes, cables etc. exceeding 80 mm dia but not exceeding 300 mm dia	Metre	25			

3	Providing and laying non-pressure NP2 class (light duty) R.C.C. pipes with collers jointed with stiff mixture of cement mortar in the proportion of 1:2 (1 cement :2 fine sand) including testing of joints etc. complete :					
4	150 mm dia. R.C.C. pipe	Metre	25			
	SANATARY WARE					
5	Providing and fixing water closet squatting pan (Indian type W.C. pan) with 100 mm sand cast Iron P or S trap, 10 litre low level white P.V.C. flushing cistern, including flush pipe, with manually controlled device (handle lever) conforming to IS : 7231, with all fittings and fixtures complete, including cutting and making good the walls and floors wherever required:					
6	White Vitreous china Orissa pattern W.C. pan of size 580x440 mm with integral type foot rests	Each	2			
	URINAL					
7	Providing and fixing white vitreous china flat back or wall corner type lipped front urinal basin of 430x260x350 mm and 340x410x265 mm sizes respectively with automatic flushing cistern with standard flush pipe and C.P. brass spreaders with brass unions and G.I clamps complete, including painting of fittings and brackets, cutting and making good the walls and floors wherever required : One urinal basin with 5 litre white P.V.C. automatic flushing cistern	Each	2			
	Wash Basin					
8	Providing and fixing wash basin with C.I. brackets, 15 mm C.P. brass pillar taps, 32 mm C.P. brass waste of standard pattern, including painting of fittings and brackets, cutting and making good the walls wherever require:					
9	White Vitreous China Wash basin size 550x400 mm with a pair of 15 mm C.P. brass pillar taps	Each	2			
10	Providing and fixing PTMT soap Dish Holder having length of 138mm, breadth 102mm, height of 75mm with concealed fitting arrangements, weighing not less than 106 gms.	Each	2			
11	PTMT Soap Dish/Holder 138x102x75 mm each	Each	2			
	TOWEL RAIL,TOWEL RACK & TOWEL RING					
12	Providing and fixing PTMT towel ring trapezoidal shape 215 mm long, 200 mm wide with minimum distances of 37 mm from wall face with concealed fittings arrangement of approved quality and colour, weighing not less than 88 gms.	each	2			
13	PTMT - Towel Ring 215x200x37 mm	each	2			
14	PTMT - Towel Rail (450 mm long)	each	2			

15	Bottle trap 31mm single piece moulded with height of 270 mm, effective length of tail pipe 260 mm from the centre of the waste coupling, 77 mm breadth with 25 mm minimum water seal, weighing not less than 260 gms	each	2			
16	Providing and fixing mirror of superior glass (of approved quality) and of required shape and size with plastic moulded frame of approved make and shade with 6 mm thick hard board backing :					
17	Circular shape 450 mm dia	each	2			
18	Providing and fixing C.P. brass long nose bib cock of approved quality conforming to IS standards and weighing not less than 810 gms.					
19	15 mm nominal bore	each	4			

NAME OF PROJECT :- CONSTRUCTION OF FRUITS AND VEGETABLE PROCESSING UNIT,AT AMBINONG, WEST KARBI ANGLONG.						
FIREFIGHTING-AS PER SPECIFICATIONS MENTIONED IN ITEMS DESCRIPTION OF THE ESTIMATE						
Item No.	FIRE EXTINGUISHER	Unit	Qty	Rate in INR		Amount
				In figure	In words	
1	Supply, Installation, Fixing of ABC stored Pressure Fire Extinguisher with built – In Pressure Gauge to know the Ready ness of the Extinguisher Squeeze Grip Handle as per IS:13849 with ISI mark. (Fire Ext MAP50 4KG MS SP Red) BRAND : FIRESTOP / FIREND / FIRE SHIELD	each	3			
2	Supply, Installation, Fixing of Pressure CO2 Fire Extinguisher with built – In Pressure Gauge to know the Ready ness of the Extinguisher Squeeze Grip Handle as per IS:13849 with ISI mark. (Fire Ext CO2 2KG Aluminium squeeze Grip SP Red)	each	2			

Note:

Item for which no rate or price has been entered in will not be paid for by the Employer when executed and shall be deemed covered by the other rates and prices in the Bill of Quantities (refer :ITB Clause 14.2 and GCC Clause 41.3)

Unit rates and prices shall be quoted by the bidder in Indian Rupees [ITB Clause 14.1 and ITB Clause 15.1]

Where there is a discrepancy between the unit rate and the line item total resulting from multiplying the unit rate by quantity, the unit rate quoted shall govern as explained in [ITB Clause 36.1]. [Note: delete this point if the e-procurement system automatically calculates the total from the unit rate and quantity]

Where there is a discrepancy between the rate in figures and words, the rates in words will govern.[ITB Clause 36.1] [Note: delete this point if the e-procurement system automatically populates the amount in words from the amount in figures]

A provisional sum (Fixed Amount) for the unknown items of resettlement of existing temporary market sheds is provided which will be operated at the instruction of Engineer-in-Charge. The Bidders shall quote the same amount as appeared in the last row of BOQ Schedule in their own BOQ Schedule submitted in Financial Bids. As the amount is fixed for all the bidders, the amount shall not be calculated in deciding the financial proposals of the bidders.

All Specification are as per World Bank Civil Works is applicable.

We agree to execute the works in accordance with the approved drawings and technical specifications at a total fixed contract price quoted by us in the Letter of Bid

Signature of Contract

DRAWINGS

- 1. Site Plan**
- 2. Building Plan**
- 3. Foundation Plan & Detail**
- 4. Plinth Beam Plan & Detail**
- 5. Roof Plan**
- 6. Storm Water Layout**
- 7. Sewerage Layout**
- 8. Typical Road Section**



STRUCTO CREATIONS (STRUCTURE CONSULTANT)
JAGAT RAM PARK LAXMI NAGAR, NEW DELHI-110092 EMAIL : msansari6313@gmail.com
CLIENT/SPV : M/s. Hammen Natural food processing Pvt.Ltd Near Ambinong weekly Market, PO&PS : Hamen, West Karbi Anglong, assam. Pin:782486
NAME OF PROJECT : Food and vegetable processing unit Near Ambinong weekly Market, PO&PS : Hamen, West Karbi Anglong, assam. Pin:782486
Drawing Title : BUILDING PLAN
Drawn By :- Saeed Ansari
Date : 20.05.2021
Drawing No - 02
PURPOSE : TENDER DRAWING
REVISION : -

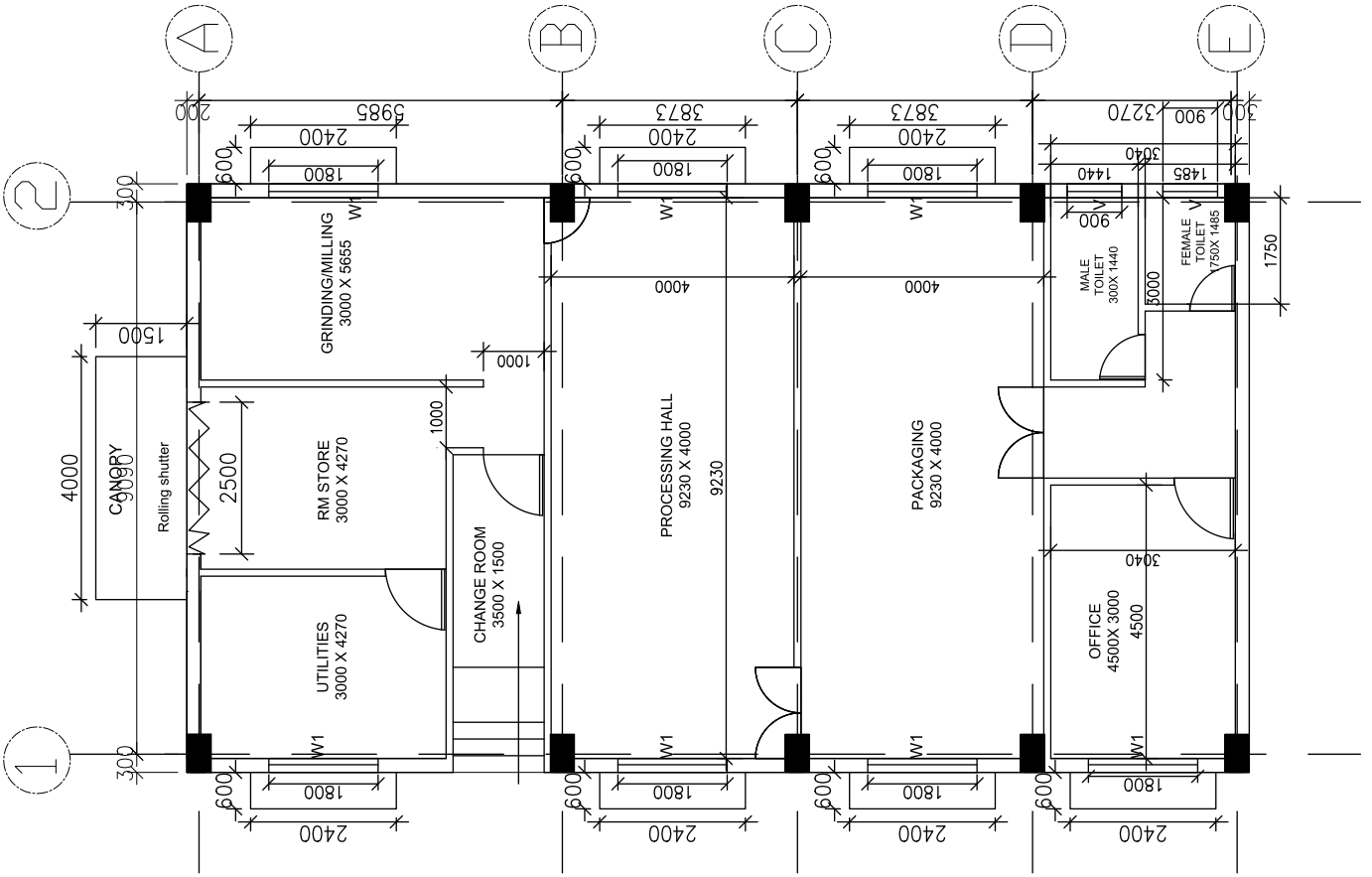

GENERAL NOTES -

NOTES & REFERENCES

1. READ THE DRAWING IN CONJUNCTION WITH RELEVANT ARCHITECTURAL DRAWINGS. ANY DISCREPANCY IF FOUND SHALL BE REPORTED TO THE ARCHITECT IMMEDIATELY.
2. ALL DIMENSIONS ARE IN MM & LEVELS IN MILLIMETERS.
3. DO NOT SCALE ANY DIMENSIONS.
4. ARCH. DRGS. TAKE PRECEDENCE OVER CIVIL DRGS. WITH RELEVANT DETAILS.
5. THE REINFORCEMENT SHALL BE AS FOLLOWS:-
6. THE CLEAR COVER TO THE REINFORCEMENT SHALL BE AS FOLLOWS:-
 - (a) FOUNDATION : 50 MM
 - (b) COLUMNS : 40 MM
 - (c) BEAMS (top & bottom) : 30 MM side cover 25mm
 - (d) SLABS : 25 MM
 - (e) CHAJJAS/CANOPY : 30 MM
7. R.C.C. WALL : 30 MM (EARTH FACE) & 25MM (INNER FACE)
8. REINFORCEMENT SHALL BE PROVIDED IN TWO LAYERS IN TOP LAYS CLOSE TO THE MID SPAN IN BOTTOM BARS & CLOSE TO SUPPORTS IN TOP BARS SHALL BE ANCHORED TO THE FULL DEVELOPMENT LENGTH.
9. INDICATES TOP BARS
10. INDICATES BOTTOM BARS
11. INDICATES REINFORCEMENT ELEMENT
12. BACK WORK
13. ALL REINFORCEMENT SHALL BE MACHINELY WELDED AND SURED THOROUGHLY AS PER IS 156-LATEST.
14. ALL REINFORCEMENT SHALL BE CENTRALLY PLACED WITH RESPECT TO THE CENTER LINE OF COLUMN.
15. REINFORCEMENT SHALL BE PROVIDED IN TWO LAYERS WHEREVER FOUND NECESSARY AND AS PER ARCHITECT'S DRAWINGS.
16. REINFORCEMENT SHALL BE PROVIDED BETWEEN TWO LAYERS OF REINFORCEMENTS AS PER IS 456.
17. ANY DISCREPANCY MUST BE CHECKED WITH ARCHITECT'S DRGS & IN CASE OF ANY DISCREPANCY ARCHITECT'S DRGS SHALL PREVAIL.
18. ALL CONSTRUCTION JOINTS SHALL BE APPROVED BY CONSULTANT ON THE BASIC OF THE DRAWING.
19. TOP AND BOTTOM EXTRA BARS IN BEAMS TO EXTEND BEYOND THE FACE OF SUPPORT AS SHOWN IN DRG UNLESS OTHERWISE SHOWN OR FROM THE JOINT FACE. THE SPECIAL CORNER REINFORCEMENT SHALL BE PROVIDED AS SHOWN IN DRG UNLESS OTHERWISE SPECIFIED.
20. PROVIDE DIST STEEL OVER EXTRA TOP BARS @ 80MM @ 200 C/C (P)
21. @ 80MM @ 200 C/C (P)
22. BLACK BOTTOM SOIL IF ENCOUNTERED IN FIN FITS, SHALL BE FULLY REMOVED.
23. ALL LOOSE PROBERTS OF SOIL BELOW FOUNDATION SHALL BE FILLED WITH F.S.S.I.C.48



STRUCTO CREATIONS
(STRUCTURE CONSULTANT)
JAGAT RAM PARK
LAXMI NAGAR, NEW DELHI-110092
EMAIL: msansari6313@gmail.com

CLIENT/SPV :
M/s. Hammen Natural food processing Pvt.Ltd
Near Ambinong weekly Market, POBPS :
Hannong, West Karbi Anglong, Assam.
Pin:782486

NAME OF PROJECT :
Food and vegetable processing unit
Near Ambinong weekly Market, POBPS :
Hannong, West Karbi Anglong, Assam.
Pin:782486

Drawing Title :
FOUNDATION PLAN & DETAIL
Drawn By :- Saeed Ansari
Date : 20.05.2021
Drawing No - 04

PURPOSE : TENDER DRAWING
REVISION : -

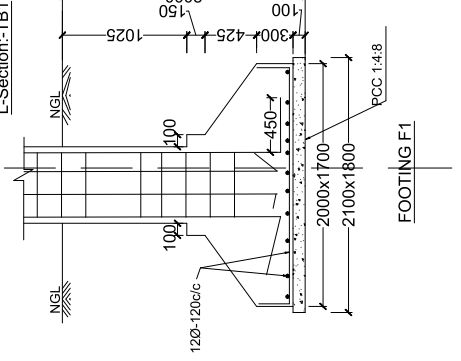
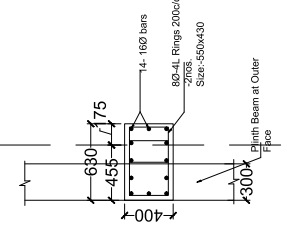
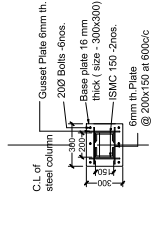
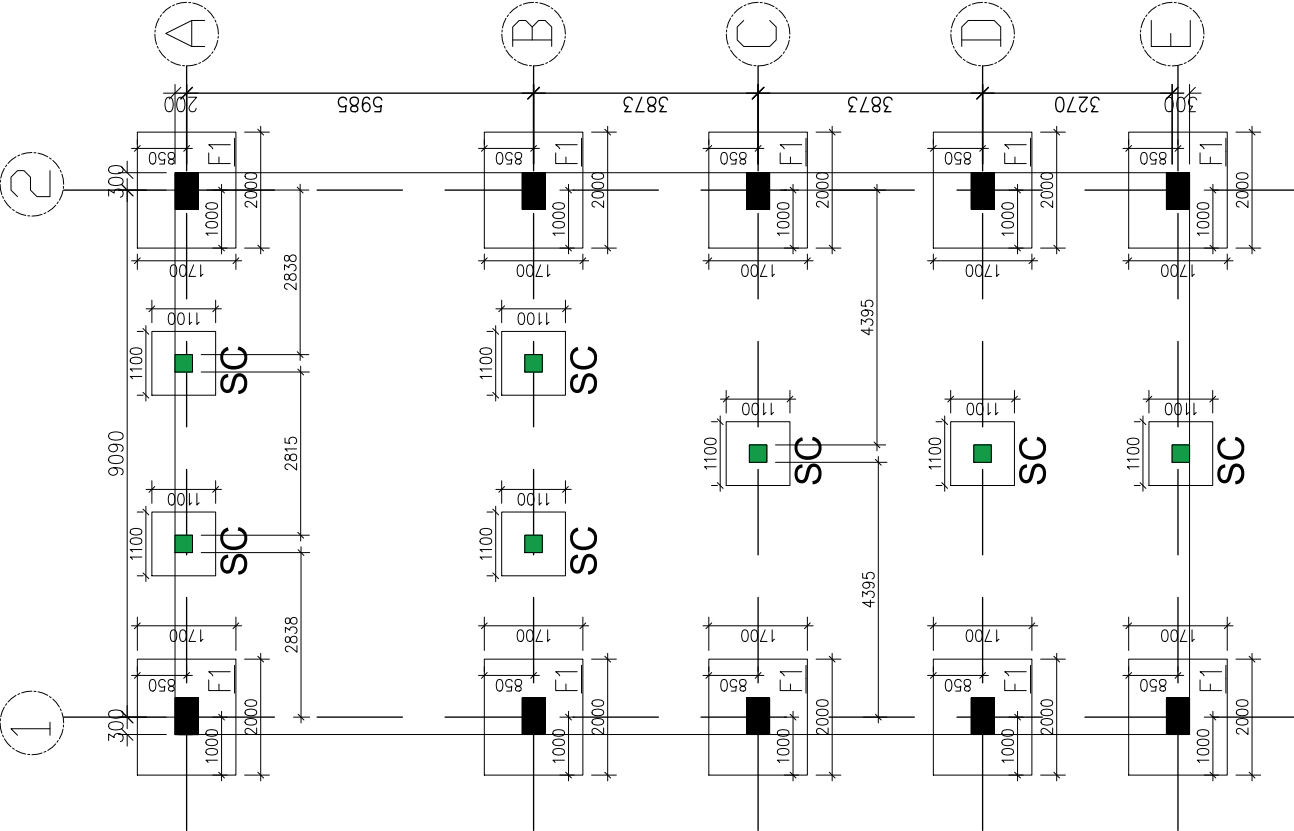

FOUNDATION LAYOUT

m:-PB1

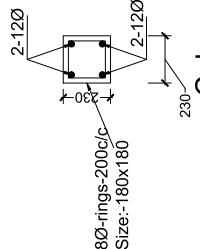
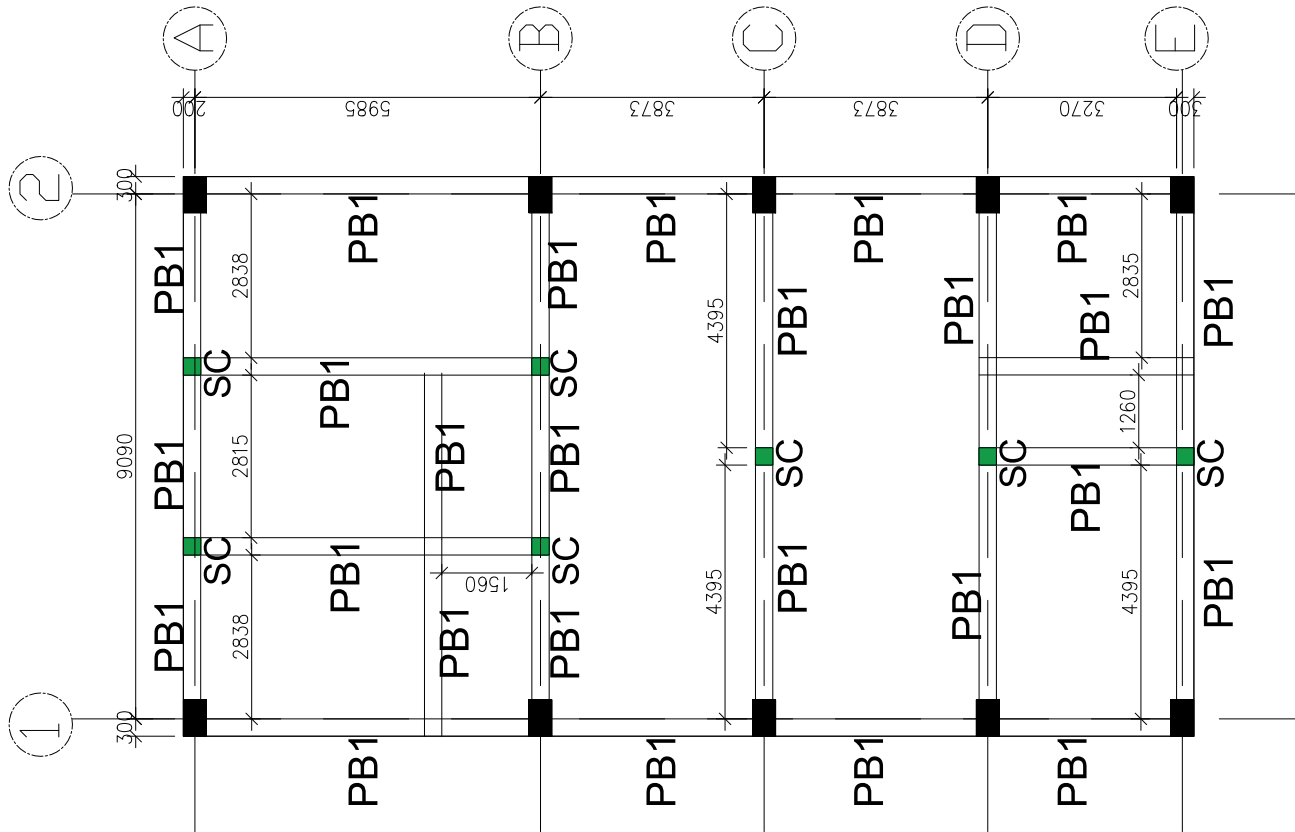

Column C1 from the pedestal reinforcement used from the pedestal

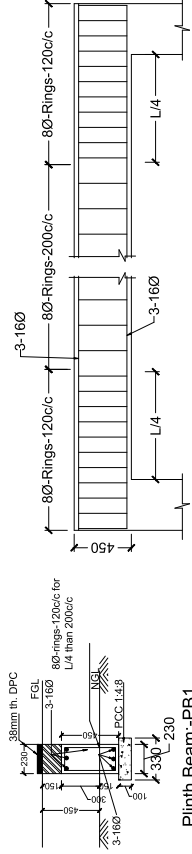
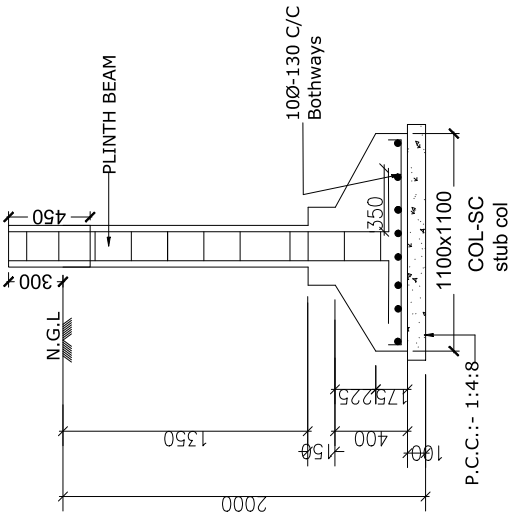
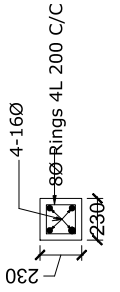

GENERAL NOTES -

NOTES & REFERENCES

1. READ THIS DRAWING IN CONJUNCTION WITH RELEVANT ARCHITECTURAL DRAWINGS. ANY DISCREPANCY IF FOUND SHALL BE REPORTED TO THE ARCHITECT IMMEDIATELY.
2. ALL DIMENSIONS ARE IN MM & LEVELS IN MILLIMETERS.
3. DO NOT SCALE ANY DIMENSIONS.
4. ALL DIMENSIONS ARE TO FACE UNLESS OTHERWISE SPECIFIED.
5. ARCH. DRS. SHALL BE CONSIDERED WITH RELEVANT DIMENSIONS.
6. THE REINFORCEMENT SHALL BE SMOOTH/STANDARD BARS (S.10) OR T.M.T. BARS HAVING YIELD STRENGTH NOT LESS THAN 500 N/mm² AND CONFORMING TO IS:1786.
7. THE CLEAR COVER TO THE REINFORCEMENT SHALL BE AS FOLLOWS:-
 (a) FOUNDATION : 50 MM
 (b) COLUMNS : 40 MM
 (c) BEAMS (top & bottom) : 30 MM side cover 25mm
 (d) SLABS : 25 MM
 (e) CHAJJAS/CANOPY : 30 MM
8. (1) R.C.C. WALL : 30 MM (EARTH FACE) & 25MM (INNER FACE)
 (2) R.C.C. WALL : 30 MM (EARTH FACE) & 25MM (INNER FACE)
 (3) R.C.C. WALL : 30 MM (EARTH FACE) & 25MM (INNER FACE)
 (4) LAPS CLOSE TO THE MID SPAN IN BOTTOM BARS & CLOSE TO SUPPORTS IN TOP BARS SHALL BE AVOIDED.
9. HATCHES INDICATE TOP BARS
 HATCHES INDICATE BOTTOM BARS
 HATCHES INDICATE FINISH ELEMENT
 HATCHES INDICATE BRICK WORK
10. ALL R.C.C. TO BE MACHINE MIXED, VIBRATED AND CURED THOROUGHLY AS PER IS 105-LATEST.
11. ALL REINFORCEMENT SHALL BE CENTRALLY PLACED WITH RESPECT TO THE CENTER LINE OF COLUMN.
12. REINFORCEMENT SHALL BE PROVIDED IN TWO LAYERS WHEREVER FOUND NECESSARY. ALL REINFORCEMENT SHALL BE PROVIDED BETWEEN TWO LAYERS OF REINFORCEMENTS AS PER IS:4463.
13. ALL DIMENSIONS MUST BE CHECKED WITH ARCHITECT'S DRS. & IN CASE OF ANY DISCREPANCY ARCHITECT'S DRS. SHALL PREVAIL.
14. ALL CONSTRUCTION JOINTS SHALL BE APPROVED BY CONSULTANT ON THE BASIC OF ARCHITECT'S DRS. & IN CASE OF ANY DISCREPANCY ARCHITECT'S DRS. SHALL PREVAIL.
15. TOP AND BOTTOM EXTRA BARS IN BEAMS TO EXTEND BEYOND THE FACE OF SUPPORT AS SHOWN IN DRG UNLESS OTHERWISE SPECIFIED.
16. ALL CONSTRUCTION JOINTS SHALL BE APPROVED BY CONSULTANT ON THE BASIC OF ARCHITECT'S DRS. & IN CASE OF ANY DISCREPANCY ARCHITECT'S DRS. SHALL PREVAIL.
17. ALL ANGLES AND RIGHT ANGLES UNLESS OTHERWISE SPECIFIED.
18. PROVIDE DIST STEEL OVER EXTRA TOP BARS @ 80MM C/C (R)
 @ 80MM C/C (R)
19. BLACK BOTTOM SOIL IF ENCOUNTERED IN FIN FRT. SHALL BE FULLY REMOVED.
20. ALL LOOSE PORTETS OF SOIL BELOW FOUNDATION SHALL BE FILLED WITH F.S.S:14.8



STRUCTO CREATIONS (STRUCTURE CONSULTANT)
JAGAT RAM PARK LAXMI NAGAR, NEW DELHI-110092 EMAIL: msansari6313@gmail.com
CLIENT/SPV : M/s. Hammen Natural food processing Pvt.Ltd Near Ambhoring weekly Market, PO&PS : Hamen, West Karbi Anglong, assam. Pin:782486
NAME OF PROJECT : Food and vegetable processing unit Near Ambhoring weekly Market, PO&PS : Hamen, West Karbi Anglong, assam. Pin:782486
Drawing Title : PLINTH BEAM PLAN & DETAIL
Drawn By :- Saeed Ansari
Date : 20.05.2021
Drawing No :- 05
PURPOSE : TENDER DRAWING
REVISION : -

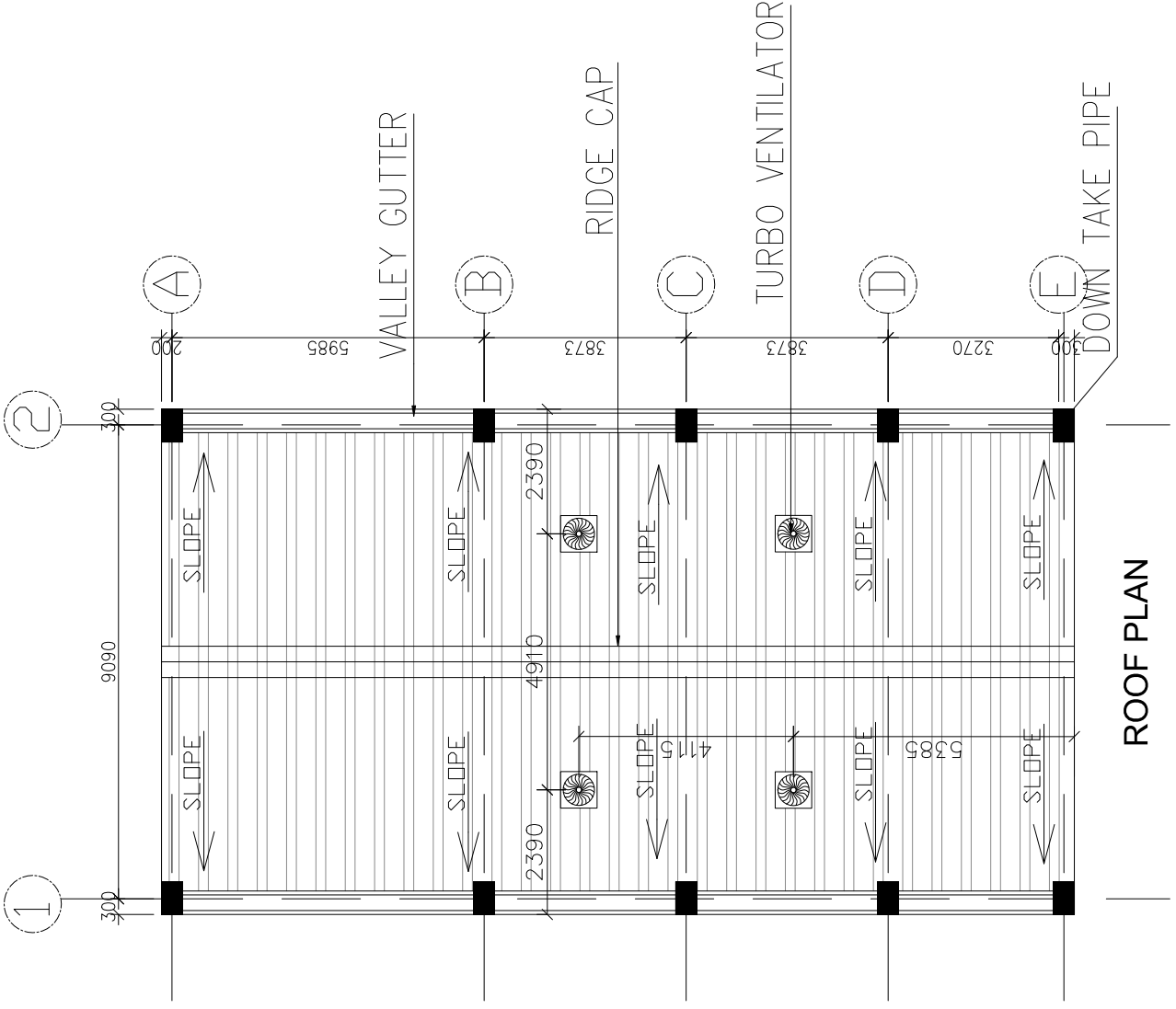

ROOF PLAN



STRUCTO CREATIONS (STRUCTURE CONSULTANT)
JAGAT RAM PARK LAXMI NAGAR, NEW DELHI-110092 EMAIL : msansari6313@gmail.com
CLIENT/SPV : M/s. Hamren Natural food processing Pvt.Ltd Near Ambicing weekly Market, PO&PS : Hamren, West Karbi Anglong, assam. Pin:782486
NAME OF PROJECT : Food and vegetable processing unit Near Ambicing weekly Market, PO&PS : Hamren, West Karbi Anglong, assam. Pin:782486
Drawing Title : ROOF PLAN
Drawn By :- Saeed Ansari
Date : 20.05.2021
Drawing No - 06
PURPOSE : TENDER DRAWING
REVISION : -



STRUCTO CREATIONS
STRUCTURE CONSULTANTS
 R-210, Basement, Laxmi Nagar,
 New Delhi-110092
 Lic. No. AM1778350

STRUCTO CREATIONS (STRUCTURE CONSULTANT)
JAGAT RAM PARK LAXMI NAGAR, NEW DELHI-110092 EMAIL : msansari6313@gmail.com
CLIENT/SPV : M/s. Hammen Natural food processing Pvt.Ltd Near Ambinong weekly Market, PO&PS : Hamren, West Karbi Anglong, assam. Ph:782486
NAME OF PROJECT : Food and vegetable processing unit Near Ambinong weekly Market, PO&PS : Hamren, West Karbi Anglong, assam. Ph:782486
Drawing Title : STORM WATER LAYOUT
Drawn By :- Saeed Ansari
Date : 20.05.2021
Drawing No - 11
PURPOSE : TENDER DRAWING
REVISION : -

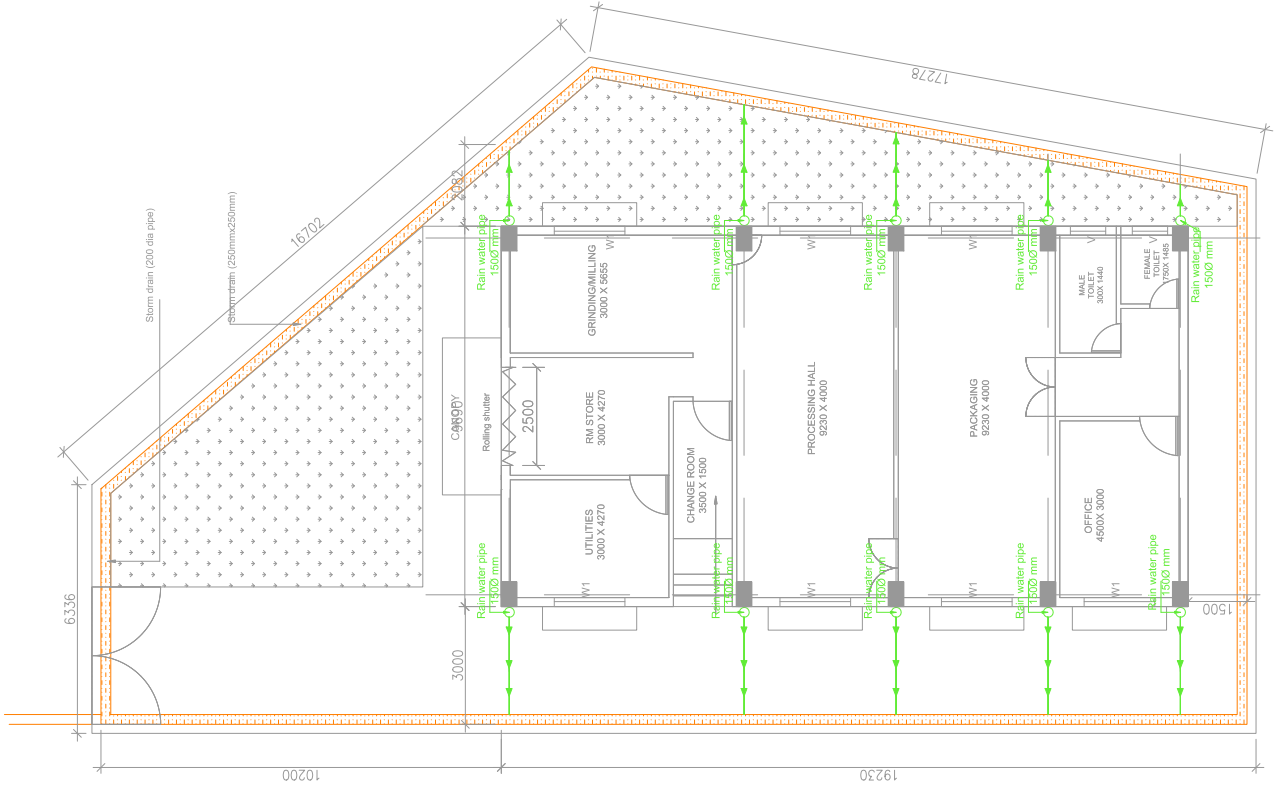

STORM WATER DRAIN



STRUCTO CREATIONS
STRUCTURE CONSULTANTS
 R-210, Basement, Laxmi Nagar,
 Delhi-110092
 Lic. No. AN1778350

STRUCTO CREATIONS (STRUCTURE CONSULTANT)
JAGAT RAM PARK LAXMI NAGAR, NEW DELHI-110092 EMAIL : msansari6313@gmail.com
CLIENT/SPV : M/s. Hammen Natural food processing Pvt.Ltd Near Ambicing weekly Market, PO&PS : Hamen, West Karbi Anglong, assam. Pin:782486
NAME OF PROJECT : Food and vegetable processing unit Near Ambicing weekly Market, PO&PS : Hamen, West Karbi Anglong, assam. Pin:782486
Drawing Title : SEWERAGE LAYOUT
Drawn By :- Saeed Ansari
Date : 20.05.2021
Drawing No - 12
PURPOSE : TENDER DRAWING
REVISION : -

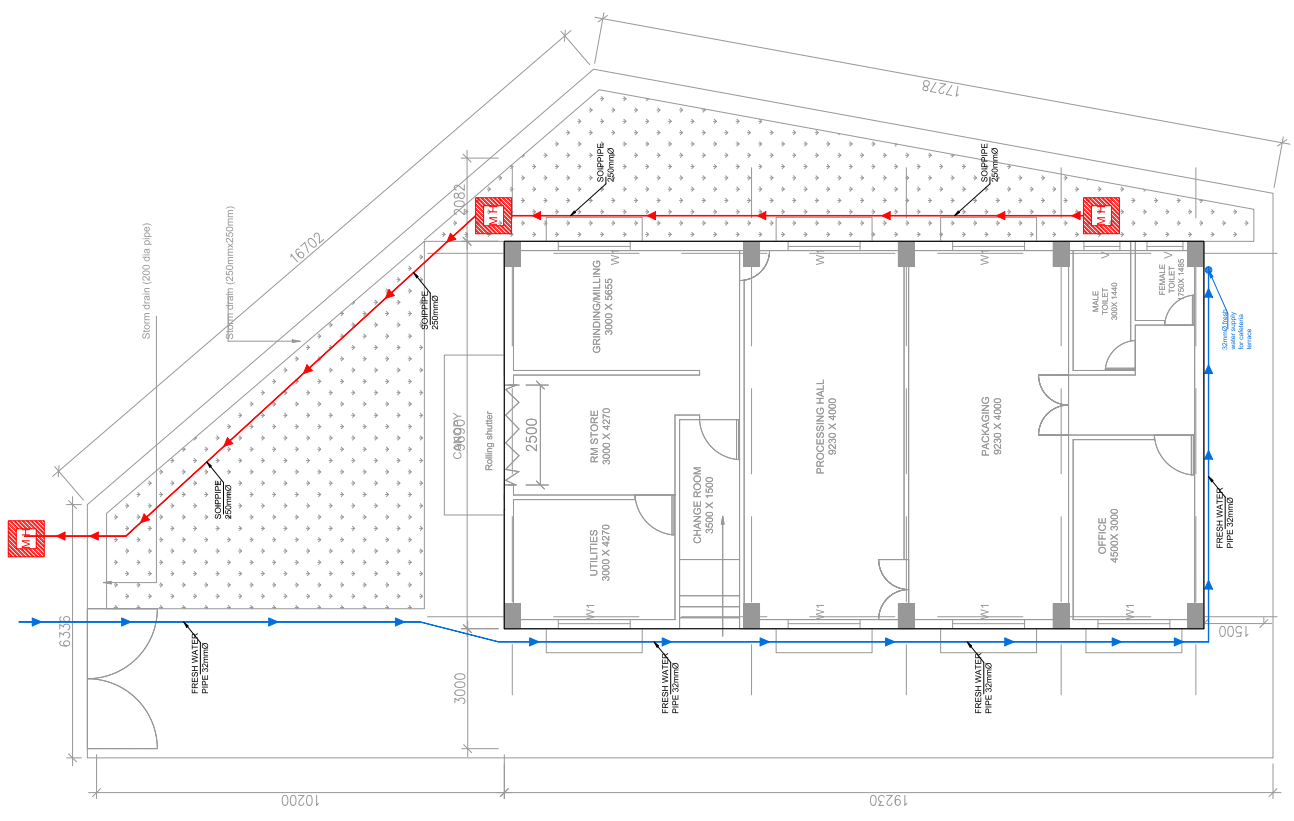

SEWERAGE LAYOUT

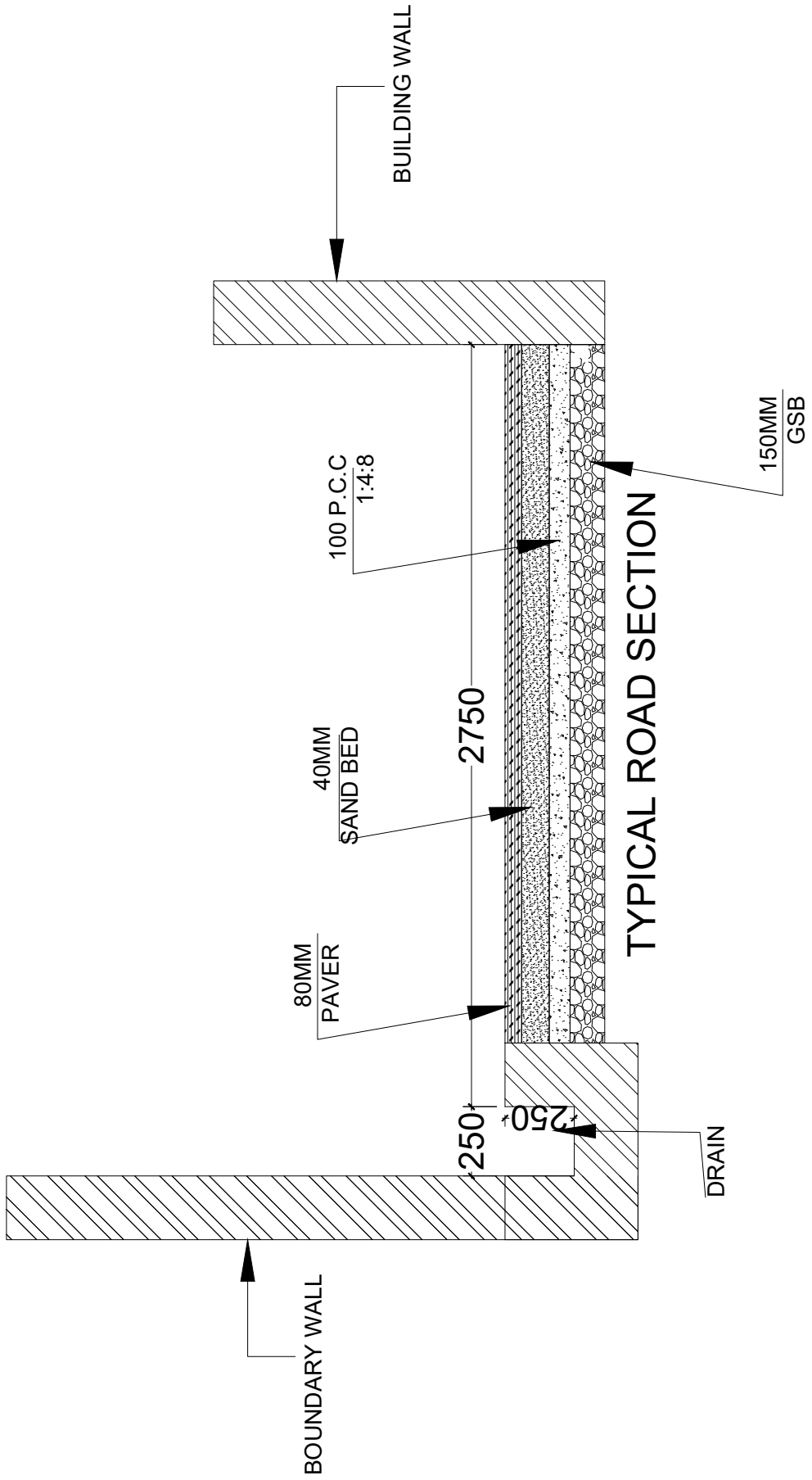

CLIENT : M/s. Hammen Natural food processing Pvt.Ltd Near Ambinong weekly Market, PO&PS : Hammen, West Karbi Anglong, assam. Pin:782486	NAME OF PROJECT : Food and vegetable processing unit. Near Ambinong weekly Market, PO&PS : Hammen, West Karbi Anglong, assam. Pin:782486
Drawing Title : TYPICAL ROAD SECTION	Date : 06.02.2023
Drawing No - 13	PURPOSE : TENDER DRAWING

Format of certificate

Certified that the works up to ----- stage (as defined in Clause 3.1 of the Agreement) in respect of construction of ----- at ----- have been executed satisfactorily in accordance with the terms and conditions of the agreement and as per approved drawings and technical specifications.

Signature
Name & Designation
(Official address)

Place:
Date:

Office seal

BANK GUARANTEE FOR ADVANCE PAYMENT

To: _____ *[name of Employer]*
_____ *[address of Employer]*
_____ *[name of Contract]*

Gentlemen:

In accordance with the provisions of the Conditions of Contract, sub-clause 3.1 of the above-mentioned Contract, _____ *[name and address of Contractor]* (hereinafter called "the Contractor") shall deposit with _____ *[name of Employer]* a bank guarantee to guarantee his proper and faithful performance under the said Clause of the Contract in an amount of _____ *[amount of guarantee]*
¹ _____ *[in words]*.

We, the _____ *[bank or financial institution]*, as instructed by the Contractor, agree unconditionally and irrevocably to guarantee as primary obligator and not as Surety merely, the payment to _____ *[name of Employer]* on his first demand without whatsoever right of objection on our part and without his first claim to the Contractor, in the amount not exceeding _____ *[amount of guarantee]*¹
_____ *[in words]*.

We further agree that no change or addition to or other modification of the terms of the Contract or of Works to be performed thereunder or of any of the Contract documents which may be made between _____ *[name of Employer]* and the Contractor, shall in any way release us from any liability under this guarantee, and we hereby waive notice of any such change, addition or modification.

This guarantee shall remain valid and in full effect from the date of the advance payment under the Contract until _____ *[name of Employer]* receives full repayment of the same amount from the Contractor.

Yours truly,

Signature and seal: _____
Name of Bank/Financial Institution: _____
Address: _____
Date: _____

¹ An amount shall be inserted by the bank or financial institution representing the amount of the Advance Payment, and denominated in Indian Rupees.

PERFORMANCE BANK GUARANTEE
(To be given from a nationalized or scheduled bank in India)

To: _____ [name of Employer]
_____ [address of Employer]

WHEREAS _____ [name and address of Contractor] (hereinafter called "the Contractor") has undertaken, in pursuance of Contract No. _____ dated _____ to execute _____ [name of Contract and brief description of Works] (hereinafter called "the Contract");

AND WHEREAS it has been stipulated by you in the said Contract that the Contractor shall furnish you with a Bank Guarantee by a recognized bank for the sum specified therein as security for compliance with his obligations in accordance with the Contract;

AND WHEREAS we have agreed to give the Contractor such a Bank Guarantee;

NOW THEREFORE we hereby affirm that we are the Guarantor and responsible to you, on behalf of the Contractor, up to a total of _____ [amount of guarantee]¹ _____ [in words], such sum being payable in the types and proportions of currencies in which the Contract Price is payable, and we undertake to pay you, upon your first written demand and without cavil or argument, any sum or sums within the limits of _____ [amount of guarantee]¹ as aforesaid without your needing to prove or to show grounds or reasons for your demand for the sum specified therein.

We hereby waive the necessity of your demanding the said debt from the Contractor before presenting us with the demand.

We further agree that no change or addition to or other modification of the terms of the Contract or of the Works to be performed there under or of any of the Contract documents which may be made between you and the Contractor shall in any way release us from any liability under this guarantee, and we hereby waive notice of any such change, addition or modification.

This guarantee shall be valid until 28 days from the date of expiry of the Defects Liability Period.

Signature and seal of the guarantor _____
Name of Bank _____
Address _____
Date _____